

SPIRAL DUCT GRILLE

MINIMUM SIZE: 10" X 3"

MAXIMUM SIZE: 48" X 12"

SINGLE AND DOUBLE (VERTICAL & HORIZONTAL) DEFLECTION

ADJUSTABLE BLADES

EXTRUDED ALUMINUM; 6063-T5

FINISH - SA (SATIN ANODIZE) OR W (WHITE PAINTED)

OPTIONAL AIR SCOOP WITH SCREW ADJUSTMENT

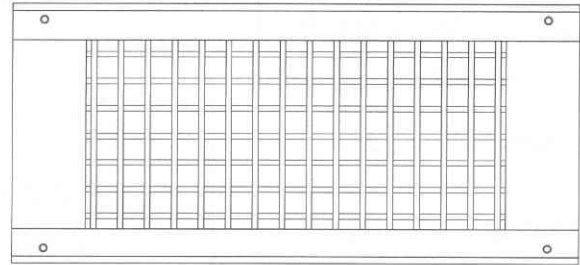

FACE VIEW

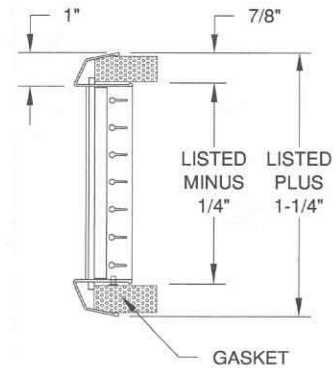
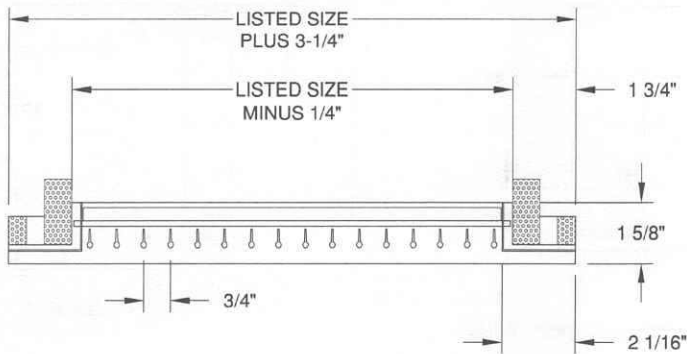

MODEL - US2V

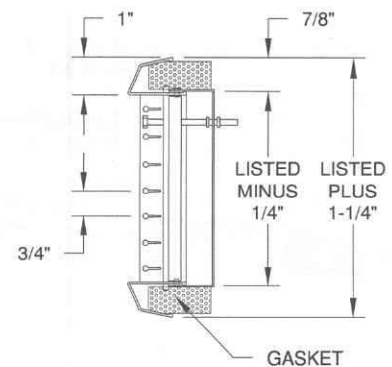
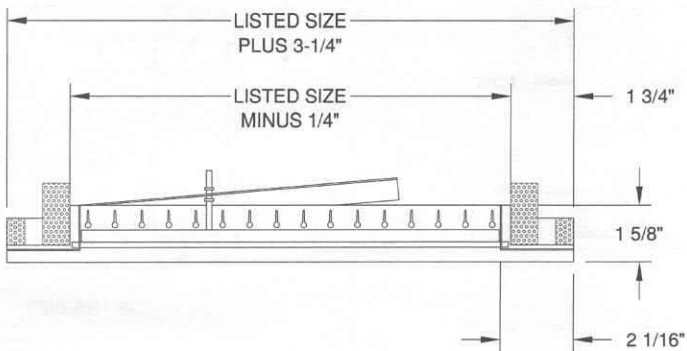

MODEL - US2H-AS

DWG NO.
02HV204A

DATE:
10/11/02

JOB NAME: _____

LOCATION: _____

ARCHITECT: _____

ENGINEER: _____

CONTRACTOR: _____

FINISH: _____