

SPIRAL DUCT GRILLE

MINIMUM SIZE: 10" X 3"

MAXIMUM SIZE: 48" X 12"

SINGLE AND DOUBLE (VERTICAL & HORIZONTAL) DEFLECTION

ADJUSTABLE BLADES

EXTRUDED ALUMINUM; 6063-T5

FINISH - SA (SATIN ANODIZE) OR W (WHITE PAINTED)

OPTIONAL AIR SCOOP WITH SCREW ADJUSTMENT

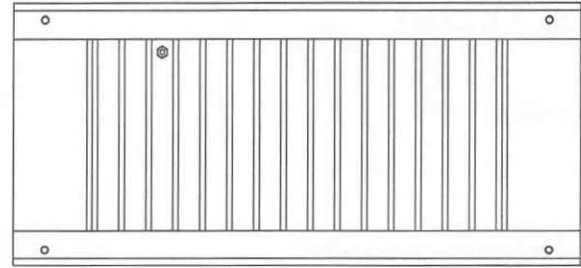

FACE VIEW

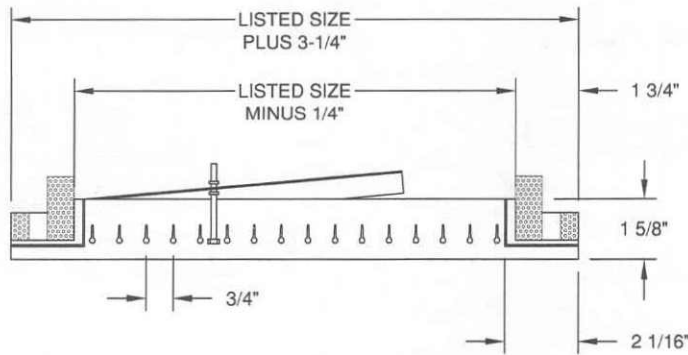

MODEL - US1V-AS

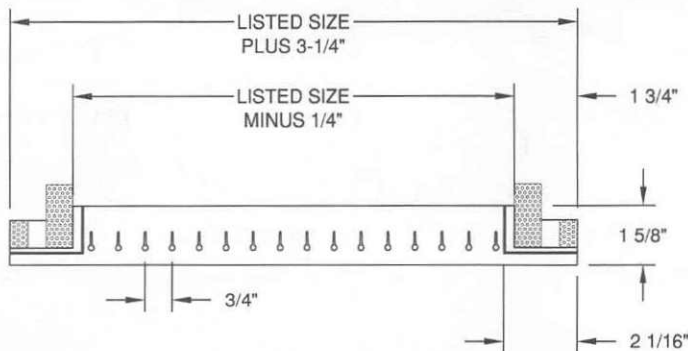
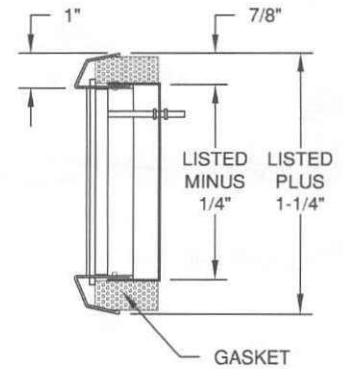

MODEL - US1V

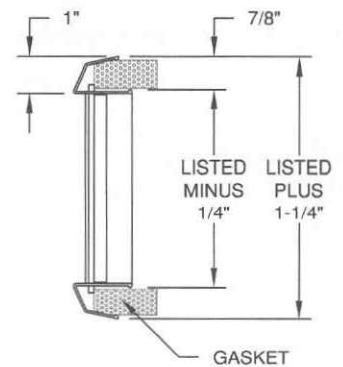

DWG NO.

02HV203A

DATE:

10/11/02

JOB NAME: _____

LOCATION: _____

ARCHITECT: _____

ENGINEER: _____

CONTRACTOR: _____

FINISH: _____