

# SUBMITTAL SHEET



N° GSA4

## Fixed 42 degree Deflection Return Grille

- GSA40** (Steel)
- GSA47** (Steel + OBD)
- GAA40** (Aluminum)
- GAA47** (Aluminum + OBD)

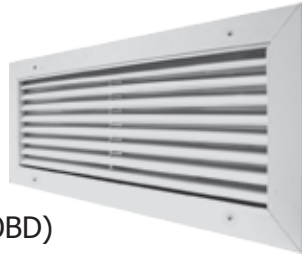

- GSA40-V** (Steel)
- GSA47-V** (Steel + OBD)
- GAA40-V** (Aluminum)
- GAA47-V** (Aluminum + OBD)

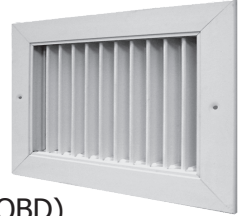

**Horizontal face bars**  
(Shown with recessed mullion, for w>18")

**Vertical face bars**

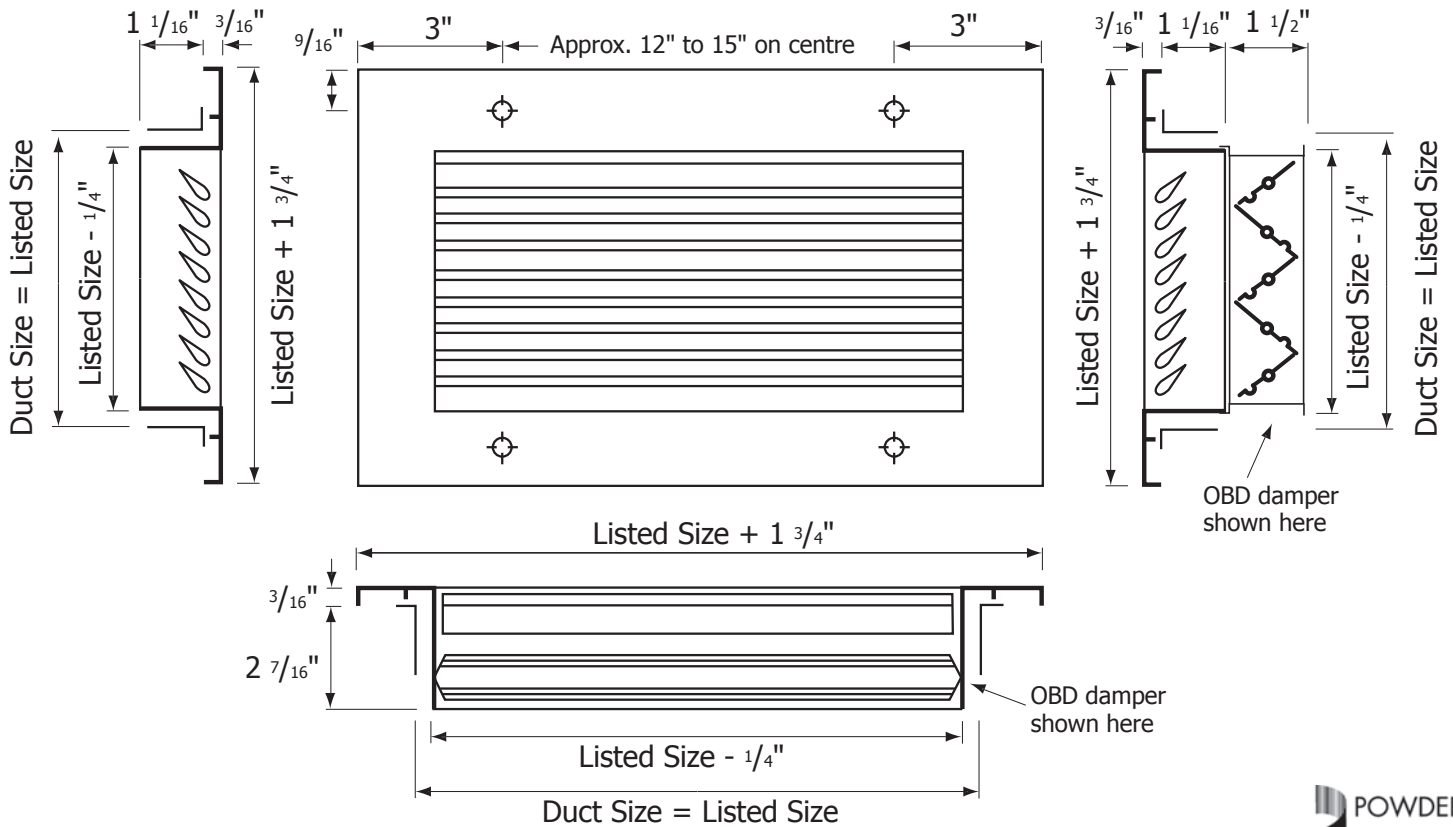

Finish	
White <input type="checkbox"/>	Custom (please specify) <input type="checkbox"/>

Job: \_\_\_\_\_

Architect: \_\_\_\_\_

Engineer: \_\_\_\_\_

Contractor: \_\_\_\_\_

#7 STEEL DAMPER FURNISHED ON LISTED WIDTHS OF 4" AND OVER (for 1" increments only)

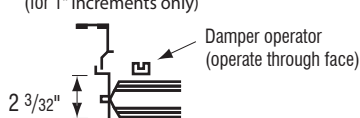

#9 STEEL DAMPER FURNISHED ON LISTED WIDTHS UNDER 4"

