

### PERFORATED SPIRAL DUCT

PERFORATED ALUMINUM FACE WITH 5/32" DIAMETER HOLES ON 3/16" CENTERS IN 60° STAGGERED ROWS 3/32" ON CENTER.

MINIMUM SIZE: 10" X 3"

MAXIMUM SIZE: 48" X 12"

EXTRUDED ALUMINUM; 6063-T5

FINISH - SA (SATIN ANODIZE) OR W (WHITE PAINTED)

OPTIONAL AIR SCOOP WITH SCREW ADJUSTMENT

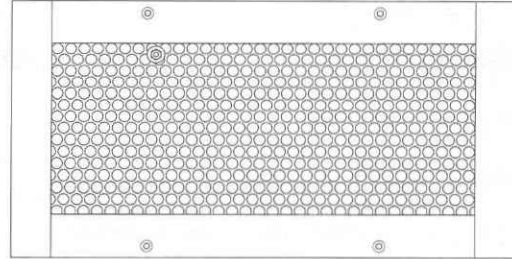

FACE VIEW

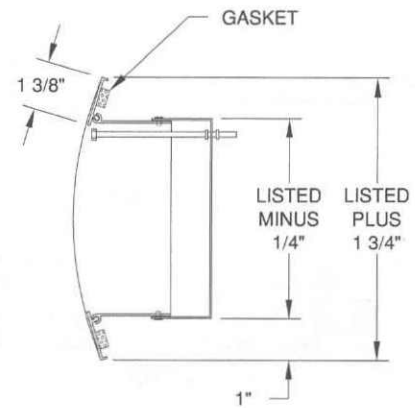
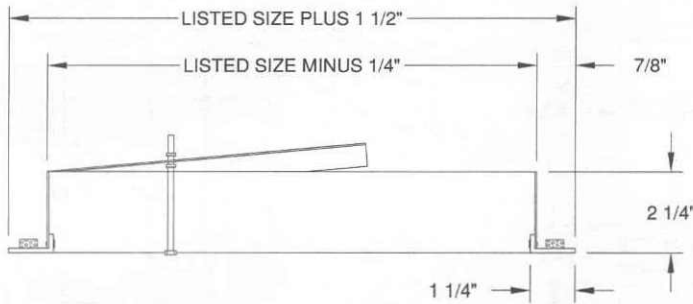

MODEL - SPF- AS

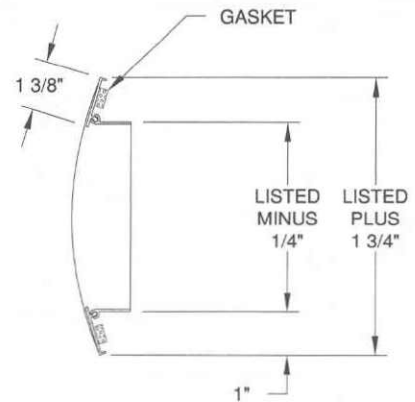
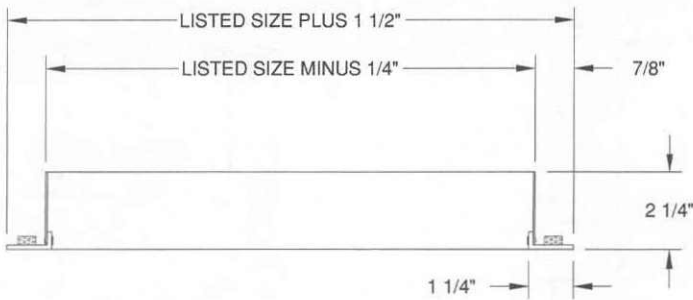

MODEL - SPF

DWG NO.

02HV205

JOB NAME: \_\_\_\_\_

ENGINEER: \_\_\_\_\_

DATE:

10/11/02

LOCATION: \_\_\_\_\_

CONTRACTOR: \_\_\_\_\_

ARCHITECT: \_\_\_\_\_

FINISH: \_\_\_\_\_