



## EQUIPMENT SUPPORT RAILS

**MODELS:**  
**LS-ESC (STEEL)**  
**LA-ESC (ALUMINUM)**



### APPLICATION

The LS-ESC/LA-ESC are Lloyd's Cant Equipment Support Rails. LA-ESC/LS-ESC pedestal with continuous wood nailer for the proper attachment of roofing flashings, along with a removable cap flashing which offers maximum assurance of a secure, watertight, installation. They provide standardized supports, fabricated from 0.063 Aluminum alloy 3003-H14(LA-ESC)/16 gauge galvanized steel (LS-ESC) with continuous welded corners, designed with the structural integrity to support the majority of all roof-mounted equipment.

### **Model: LS-ESC** **STANDARD CONSTRUCTION**

Fabricated using 16 gage galvanized steel  
Incorporates straight side walls & 2" flanges  
Internal reinforcements at 12" centers  
Factory installed wood nailer for equipment  
Mounting is mechanically fastened  
Mill finish is standard  
(optional) Rail cap available

### **Model: LA-ESC** **STANDARD CONSTRUCTION**

Fabricated using 0.063 Aluminum alloy 3003-H14  
Incorporates straight side walls & 2" flanges  
Internal reinforcements at 12" centers  
Factory installed wood nailer for equipment  
Mounting is mechanically fastened  
Mill finish is standard  
(optional) Rail cap available

OPTIONAL RAIL CAP

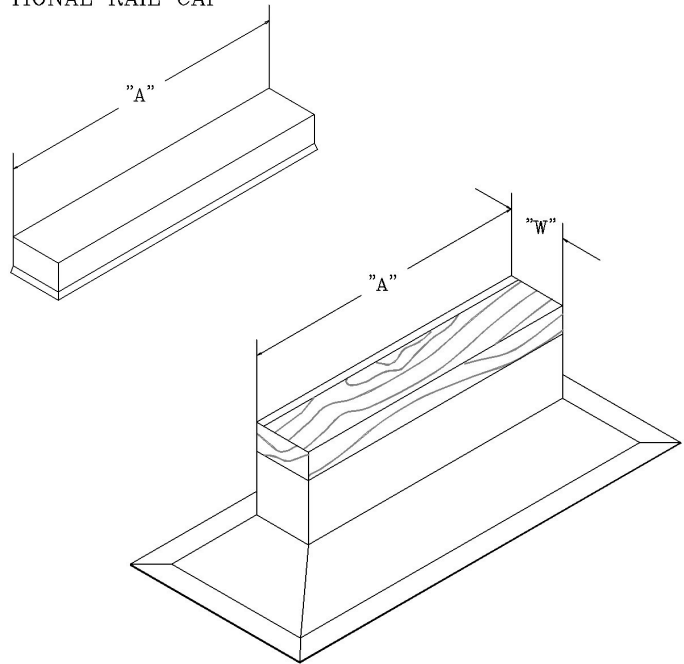

MODEL SELECTIONS		
Models	Nominal wide	Actual nailer width
LA-ESC-4/LS-ESC-4	4"	3-1/2"
LA-ESC-6/LS-ESC-6	6"	5-1/2"
LA-ESC-8/LS-ESC-8	8"	7-1/2"
LA-ESC-10/LS-ESC-10	10"	9-1/2"
LA-ESC-12/LS-ESC-12	12"	11-1/2"

