



EXTRUDED ALUMINUM BRICK VENTS



MODELS:
4-BVCF
STORM RESISTANT
(CHANNEL FRAME)

APPLICATION

The 4-BVCF is Lloyd's extruded aluminum brick vents with channel frame. Extruded construction provides a quality finished appearance. A high water stop at the rear and deep overlapping blades with storm stops provide maximum resistance to rain.

STANDARD CONSTRUCTION

- FRAME:** 1/8" Thick extruded aluminum 6063 T6
Construction with 1/4" drip ledge top and bottom
- BLADES:** 1/8" thick extruded aluminum 6063 T6 construction
- BLADE CENTERS:** 1" Centers at 45° head and sill spacing not to exceed frame flange dimension for maximum water resistance
- ASSEMBLY:** Aluminum 18x16 MESH corrosion resistant
- FINISH:** Mill finish
- OPTIONAL FINISHES:**
- (1) Clear Anodize
 - (2) Painted
 - (3) KYNAR
 - (4) Anodize colors
- SIZES:** Minimum Width 4"
Minimum Height 2-1/4"
Maximum single section: Unlimited

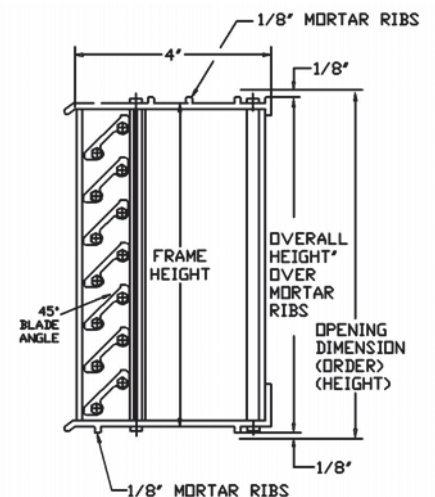
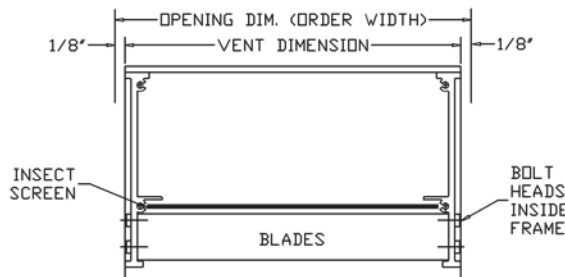
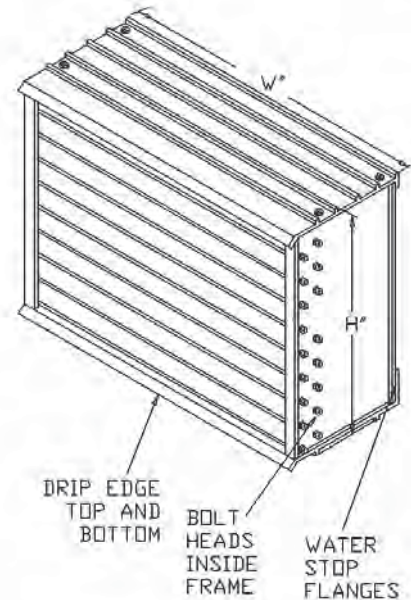

Brick vent will be supplied as order width -1/4" x order height -1/4" unless specified "actual size."