

DAMPER INSTALLATION INSTRUCTIONS

INSTALLATION AND MAINTENANCE INSTRUCTIONS

1-1/2 HOUR RATED, UL CLASSIFIED FIRE DAMPER

FOR USE IN FIRE BARRIERS WITH RATINGS OF LESS THAN 3 HOURS

INSPECTION

Inspect for shipping damage.
Inspect for proper size and model.
Inspect installed damper for proper orientation, as stated on damper label.
Inspect for obstructions which could interfere with free operation and complete closure.
Manually cycle the damper to verify proper operation.

TYPICAL WALL INSTALLATION

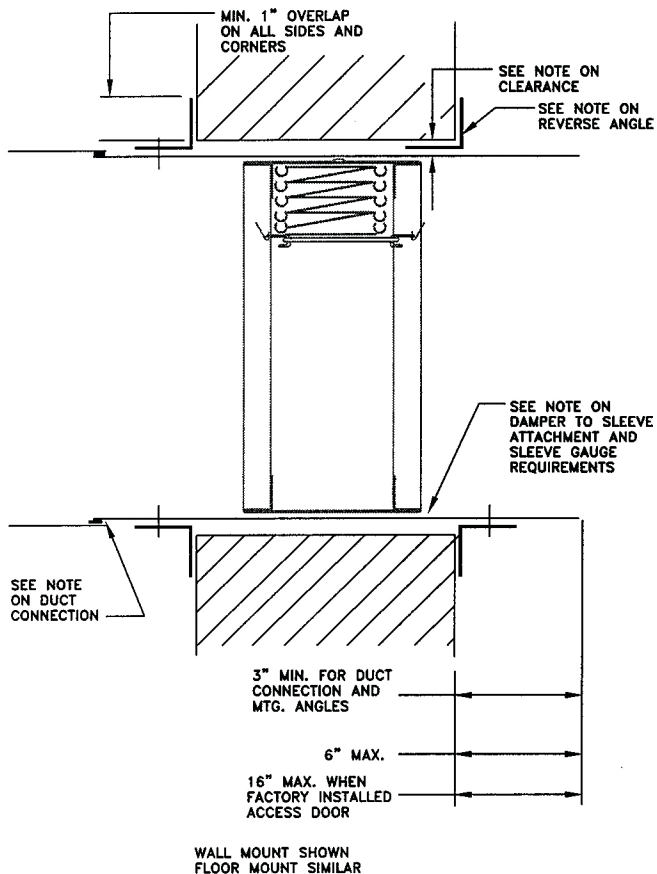

INSTALLATION

The basic intent of a proper installation is to secure the fire damper in, not to, the opening in such a manner as to prevent distortion and disruption of the damper operation by allowing the fire damper in openings to expand and the connecting duct to separate in the event of the collapse of the hanging system. The fire damper must be positioned within the masonry, block or gypsum wallboard fire barrier. Reference page 5 for details of a suggested drywall partition.

DAMPER TO SLEEVE ATTACHMENT

A Sleeve shall be used of sufficient length to permit direct attachment of perimeter mounting angles. This damper can be supplied by the factory mounted in a sleeve. If the sleeve is not factory supplied, it must be attached on both sides of the damper by one of the following methods:
Secure with 1/4" dia. bolts and nuts or by welding with beads 1/2" in length, or with No. 10 steel sheet metal screws, or 3/16" steel rivets. Fasteners shall be 8" maximum on centers. Fasteners cannot be placed where they will interfere with damper operation. Gaps at corners between the damper and its sleeve must be small enough to prohibit the passage of an 1/8" diameter rod through the entire depth of the gap between two damper panels and its sleeve.

SLEEVE THICKNESS

Sleeves shall be the same gauge or heavier as the duct to which it is attached. Gauges shall conform to SMACNA or ASHRAE duct standards. Damper sleeve can be no thicker than 10 GA steel. On type C dampers, the sleeve must be 18 GA. or heavier.

EXPANSION CLEARANCE

The opening in the wall or floor for the fire damper shall be sized so as to provide expansion clearance between the sleeve and opening. Clearances do not vary with walls constructed of different materials. A minimum of 1/8" per foot of overall damper/sleeve width and height is required. The maximum opening size shall not exceed 1/8" per foot plus 1", minimum total clearance shall be at least 1/4" larger than the overall assembly.



CLLOYD-50-REV-B



WebREPS
800-810-3280

DAMPER INSTALLATION INSTRUCTIONS

INSTALLATION AND MAINTENANCE INSTRUCTIONS

1-1/2 HOUR RATED, UL CLASSIFIED FIRE DAMPER

FOR USE IN FIRE BARRIERS WITH RATINGS OF LESS THAN 3 HOURS

INSPECTION

Inspect for shipping damage.
Inspect for proper size and model.
Inspect installed damper for proper orientation, as stated on damper label.
Inspect for obstructions which could interfere with free operation and complete closure.
Manually cycle the damper to verify proper operation.

TYPICAL HORIZONTAL INSTALLATION

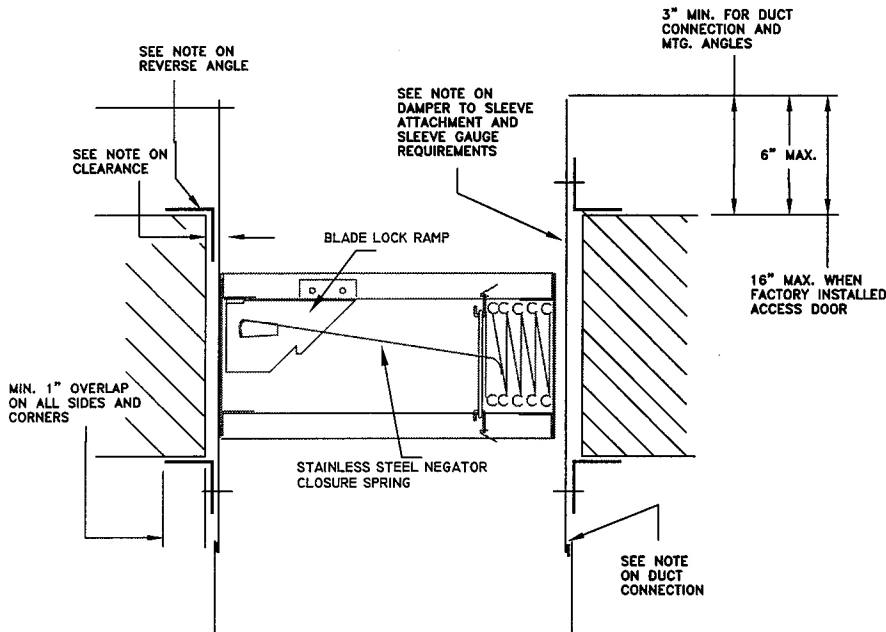

HORIZONTAL MOUNT SHOWN

INSTALLATION

The basic intent of a proper installation is to secure the fire damper in, not to, the opening in such a manner as to prevent distortion and disruption of the damper operation by allowing the fire damper in openings to expand and the connecting duct to separate in the event of the collapse of the hanging system. The fire damper must be positioned within the masonry, block or gypsum wallboard fire barrier. Reference page 5 for details of a suggested drywall partition.

DAMPER TO SLEEVE ATTACHMENT

A Sleeve shall be used of sufficient length to permit direct attachment of perimeter mounting angles. This damper can be supplied by the factory mounted in a sleeve. If the sleeve is not factory supplied, it must be attached on both sides of the damper by one of the following methods:
Secure with 1/4" dia. bolts and nuts or by welding with beads 1/2" in length, or with No. 10 steel sheet metal screws, or 3/16" steel rivets. Fasteners shall be 8" maximum on centers. Fasteners cannot be placed where they will interfere with damper operation. Gaps at corners between the damper and its sleeve must be small enough to prohibit the passage of an 1/8" diameter rod through the entire depth of the gap between two damper panels and its sleeve.

SLEEVE THICKNESS

Sleeves shall be the same gauge or heavier as the duct to which it is attached. Gauges shall conform to SMACNA or ASHRAE duct standards. Damper sleeve can be no thicker than 10 GA steel. On type C dampers, the sleeve must be 18 GA. or heavier.

EXPANSION CLEARANCE

The opening in the wall or floor for the fire damper shall be sized so as to provide expansion clearance between the sleeve and opening. Clearances do not vary with walls constructed of different materials. A minimum of 1/8" per foot of overall damper/sleeve width and height is required. The maximum opening size shall not exceed 1/8" per foot plus 1", minimum total clearance shall be at least 1/4" larger than the overall assembly.



10546-REV-A