

AIR CONTROL DAMPER

COMBINATION ASSEMBLIES
AIR CONTROL DAMPER,
LOUVER (4-SRF SHOWN)
ACTUATOR (EXTERNAL MOUNT SHOWN)
& SLEEVE

MODEL AC 10 PARALLEL BLADE
MODEL AC 20 OPPOSED BLADE

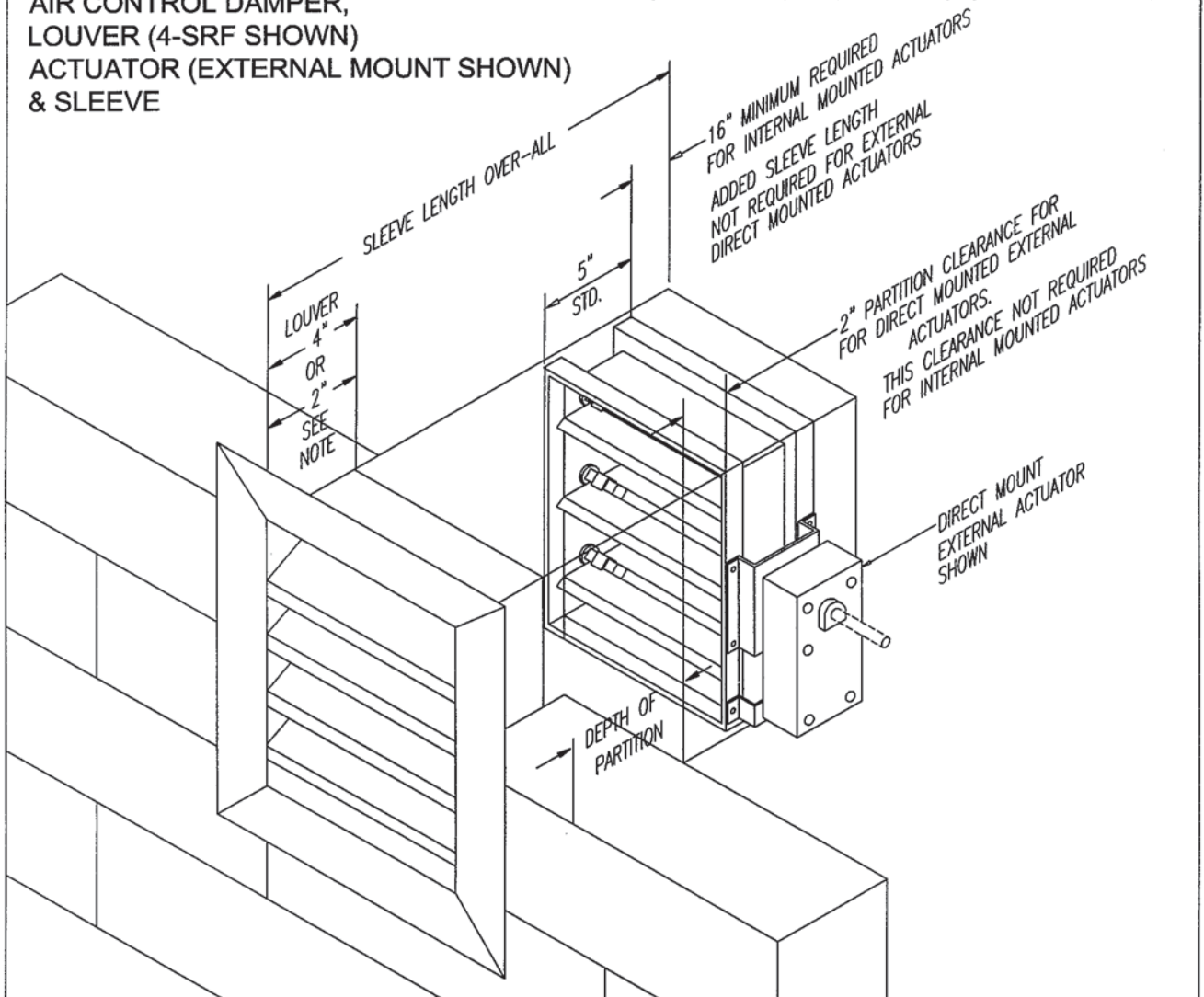

SINGLE SECTION SIZE AVAILABILITY		MULTIPLE SECTIONS	JOB NAME: _____
WIDTH X HEIGHT			
MINIMUM	6" x 6"	UNLIMITED	LOCATION: _____
MAXIMUM	60" x 60"		ARCHITECT: _____
			ENGINEER: _____
			CONTRACTOR: _____

10073-REV-A-4

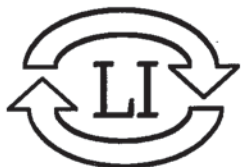

LLOYD INDUSTRIES INC.

231 COMMERCE DRIVE
MONTGOMERYVILLE, PA. 18936
TEL: 215-412-4445
FAX: 215-412-4409
EMAIL: LLOYDIND@FIREDAMPER.COM

5858 BROADWAY AVE.
JACKSONVILLE, FL. 32254
TEL: 904-378-8440
FAX: 904-378-8441
EMAIL: LLOYDINDI@BELLSOUTH.NET

WEB SITE: FIREDAMPER.COM

AIR CONTROL DAMPER

MODEL AC 10 PARALLEL BLADE

MODEL AC 20 OPPOSED BLADE

COMBINATION ASSEMBLIES
AIR CONTROL DAMPER,
LOUVER (4-SRF SHOWN)
ACTUATOR (INTERNAL MOUNT SHOWN)
& SLEEVE

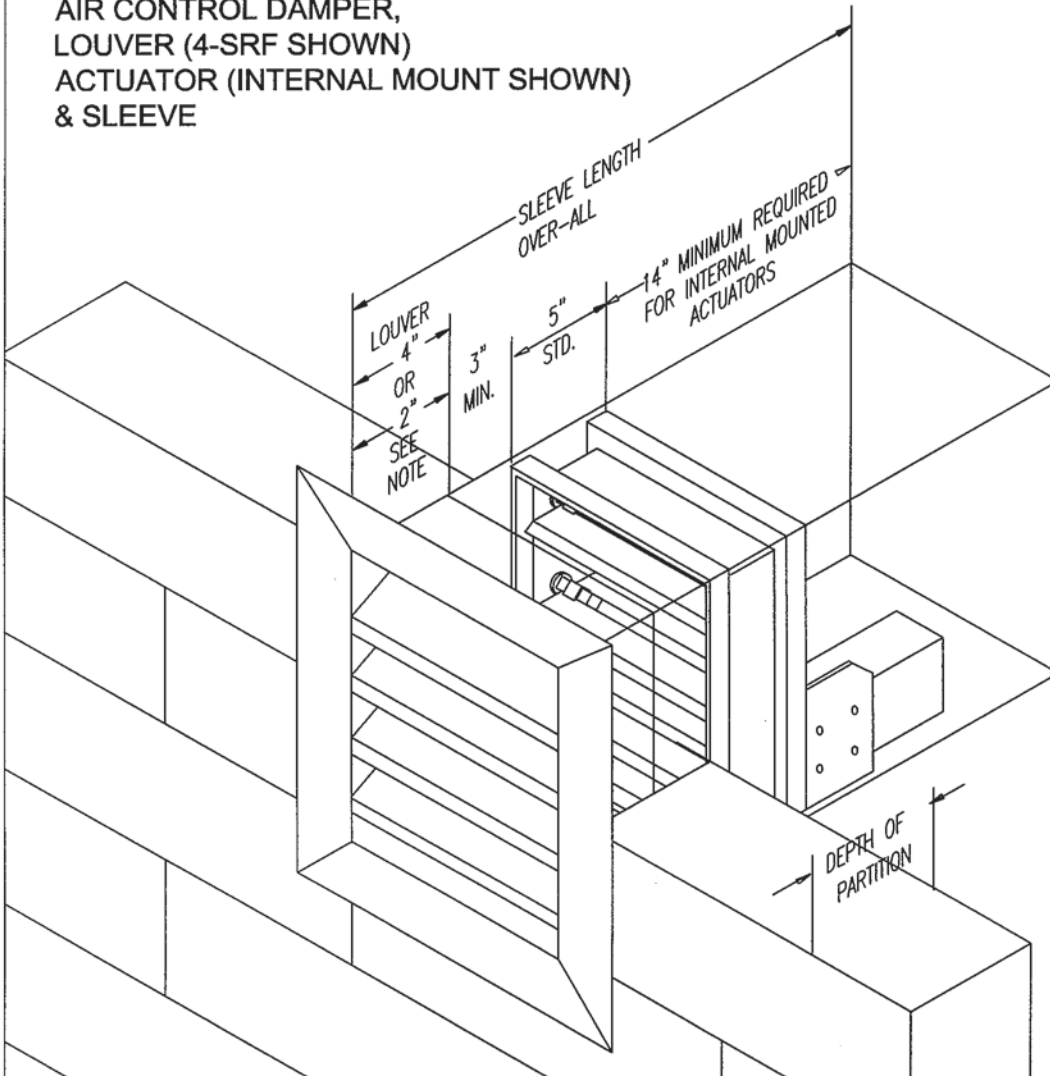

SINGLE SECTION SIZE AVAILABILITY			MULTIPLE SECTIONS	JOB NAME: _____
	WIDTH X HEIGHT			
MINIMUM	6"	6"	UNLIMITED	ARCHITECT: _____
MAXIMUM	60"	60"		ENGINEER: _____
				CONTRACTOR: _____

10073-REV-A-1

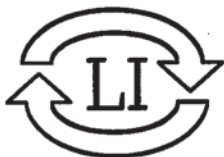

LLOYD INDUSTRIES INC.

231 COMMERCE DRIVE
MONTGOMERYVILLE, PA. 18936
TEL: 215-412-4445
FAX: 215-412-4409
EMAIL: LLOYDIND@FIREDAMPER.COM

5858 BROADWAY AVE.
JACKSONVILLE, FL. 32254
TEL: 904-378-8440
FAX: 904-378-8441
EMAIL: LLOYDINDI@BELLSOUTH.NET

WEB SITE: FIREDAMPER.COM

AIR CONTROL DAMPER

**MODEL AC 10 PARALLEL BLADE
MODEL AC 20 OPPOSED BLADE**

DIVERTER AIR CONTROL DAMPER COMBINATIONS

LINKAGE ASSEMBLY INCLUDES

- (2) Crank Arm Assemblies (10026)
- (1) Jackshaft (10025)
- (2) Bearing Brackets (10092)
- (2) Swivels

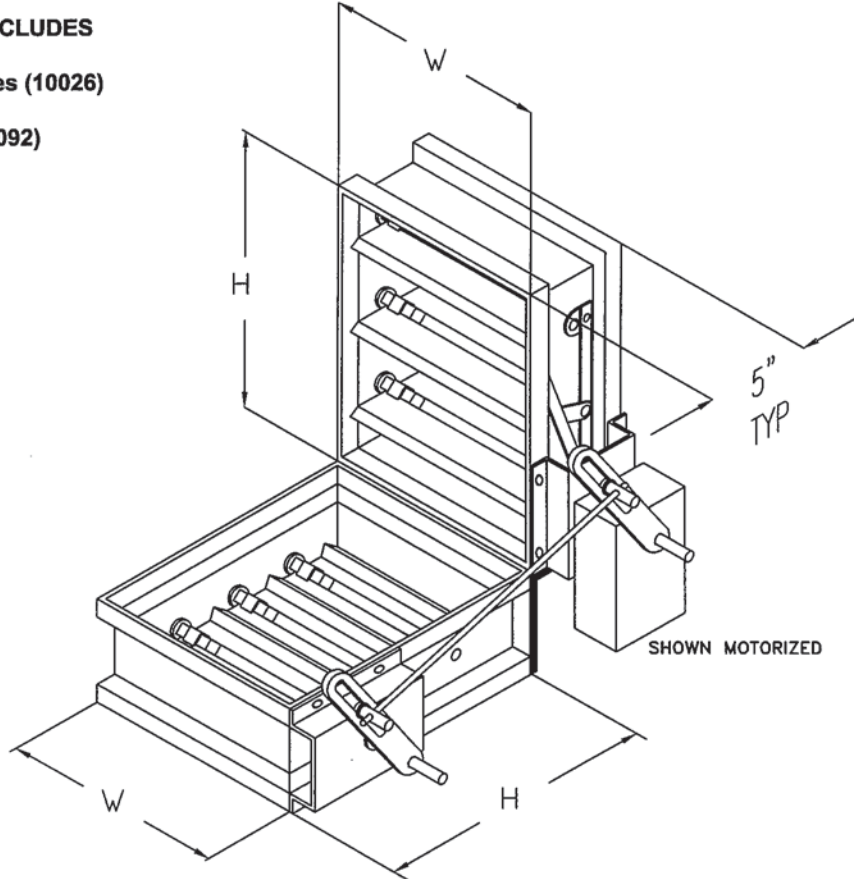

SPECIFY CONFIGURATION: (OPEN/OPEN) OR (OPEN/CLOSED)
DAMPERS SUPPLIED 1/4" LESS THAN ORDER WIDTH AND HEIGHT UNLESS SPECIFIED "ACTUAL SIZE"

SINGLE SECTION SIZE AVAILABILITY		MULTIPLE SECTIONS		JOB NAME:
MINIMUM	WIDTH X HEIGHT		UNLIMITED	LOCATION:
	6"	6"		ARCHITECT:
MAXIMUM	60" X 60"			ENGINEER:
				CONTRACTOR:

10369-REV-A



LLOYD INDUSTRIES INC.

231 COMMERCE DRIVE
MONTGOMERYVILLE, PA. 18936
TEL: 215-412-4445
FAX: 215-412-4409
EMAIL: LLOYDIND@FIREDAMPER.COM

5858 BROADWAY AVE.
JACKSONVILLE, FL. 32254
TEL: 904-378-8440
FAX: 904-378-8441
EMAIL: LLOYDINDI@BELLSOUTH.NET

WEB SITE: FIREDAMPER.COM

SLEEVES

AIR CONTROL DAMPERS

SLEEVE DIMENSIONAL INFORMATION FOR AIR CONTROL DAMPERS

MODEL AC-10 MODEL AC-20

STANDARD SLEEVES

AIR CONTROL DAMPERS CAN BE SUPPLIED WITH FACTORY MOUNTED TYPE "A" SLEEVES FOR STANDARD SYSTEM DUCTING UNLESS OTHERWISE SPECIFIED.

STANDARD "A" SLEEVE ORDERING INFORMATION

- (1) ESTABLISH DAMPER WIDTH X HEIGHT
- (2) DETERMINE THE ACTUATOR TYPE, MODEL, AND MOUNTING TYPE.
- (3) ESTABLISH THE MINIMUM ACTUATOR MOUNTING DISTANCE FROM THE MOUNTING DIAGRAMS.
- (4) DETERMINE THE SLEEVE DISTANCE "M" OPPOSITE TO THE ACTUATOR SIDE OF THE DAMPER.
- (5) ADD THE ACTUATOR MOUNTING DISTANCE TO THE "M" DISTANCE AND THE .500" DAMPER THICKNESS.
- (6) INTEGRAL FLANGES 1-1/2" WIDE CAN BE PROVIDED ON SLEEVES WHEN SPECIFIED.

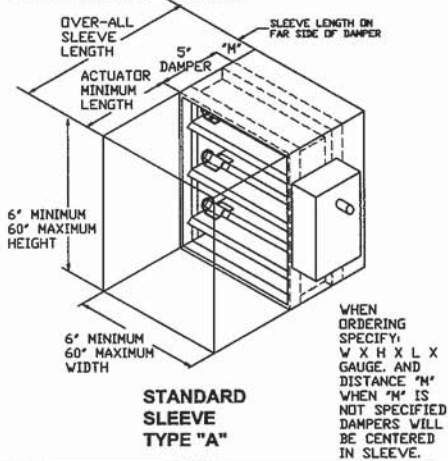

SLEEVE TRANSITIONS

AIR CONTROL DAMPERS CAN BE SUPPLIED WITH FACTORY MOUNTED SLEEVES TO TRANSITION TO ROUND, SQUARE, RECTANGULAR, OVAL OR SPECIAL SYSTEM DUCTING.

SLEEVE ORDERING INFORMATION FOR SLEEVE LENGTH CALCULATION

TYPE "CR"-ROUND:
SPECIFY THE ROUND DUCTING DIAMETER.
(THE ACTUAL DAMPER FRAME WILL BE +2.00"W X +2.00"H)

TYPE "C"-RECTANGLE:
SPECIFY THE RECTANGLE WIDTH X RECTANGLE HEIGHT
(THE ACTUAL DAMPER FRAME WILL BE +2.00"W X +2.00"H)

TYPE "CO"-OVAL:
SPECIFY THE OVAL WIDTH X OVAL HEIGHT
(THE ACTUAL DAMPER FRAME WILL BE +2.00"W X 2.00"H)

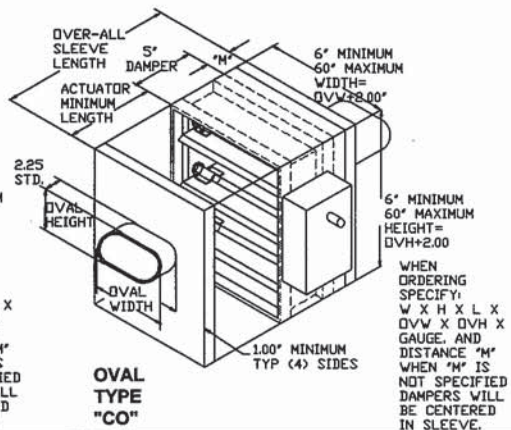
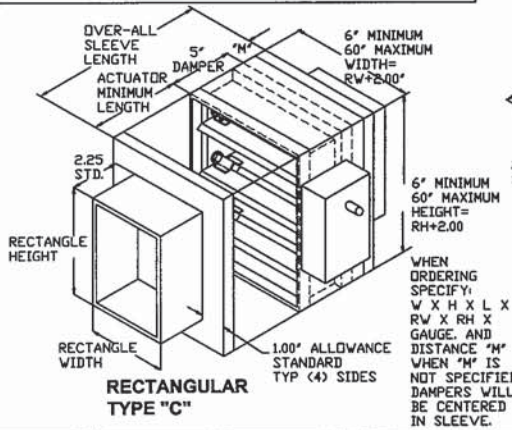
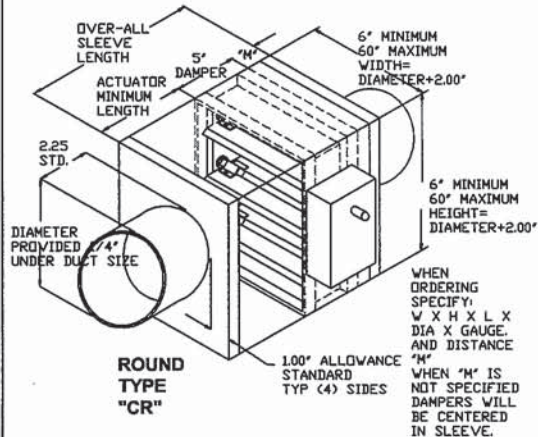

10102-REV-A

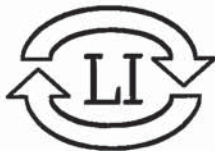

LOYD INDUSTRIES INC.

231 COMMERCE DRIVE
MONTGOMERYVILLE, PA. 18936
TEL: 215-412-4445
FAX: 215-412-4409
EMAIL: LLOYDIND@FIREDAMPER.COM

5858 BROADWAY AVE.
JACKSONVILLE, FL. 32254
TEL: 904-378-8440
FAX: 904-378-8441
EMAIL: LLOYDINDI@BELLSOUTH.NET

WEB SITE: FIREDAMPER.COM

AIR CONTROL DAMPER

MODEL AC 10 PARALLEL BLADE
MODEL AC 20 OPPOSED BLADE

DIRECT MOUNTING
EXTERNAL ACTUATOR
WITH SINGLE SIDE
COVERING SLEEVE

BELIMO (SHOWN)
POWER OPEN/SPRING CLOSE
POWER CLOSE/SPRING OPEN
POWER MODUATING
AVAILABLE IN: 120 VAC, 24VAC,
24VDC, 24VDC WITH 2-10V DC
CONTROLLING (MODULATING)
END SWITCHES AVAILABLE

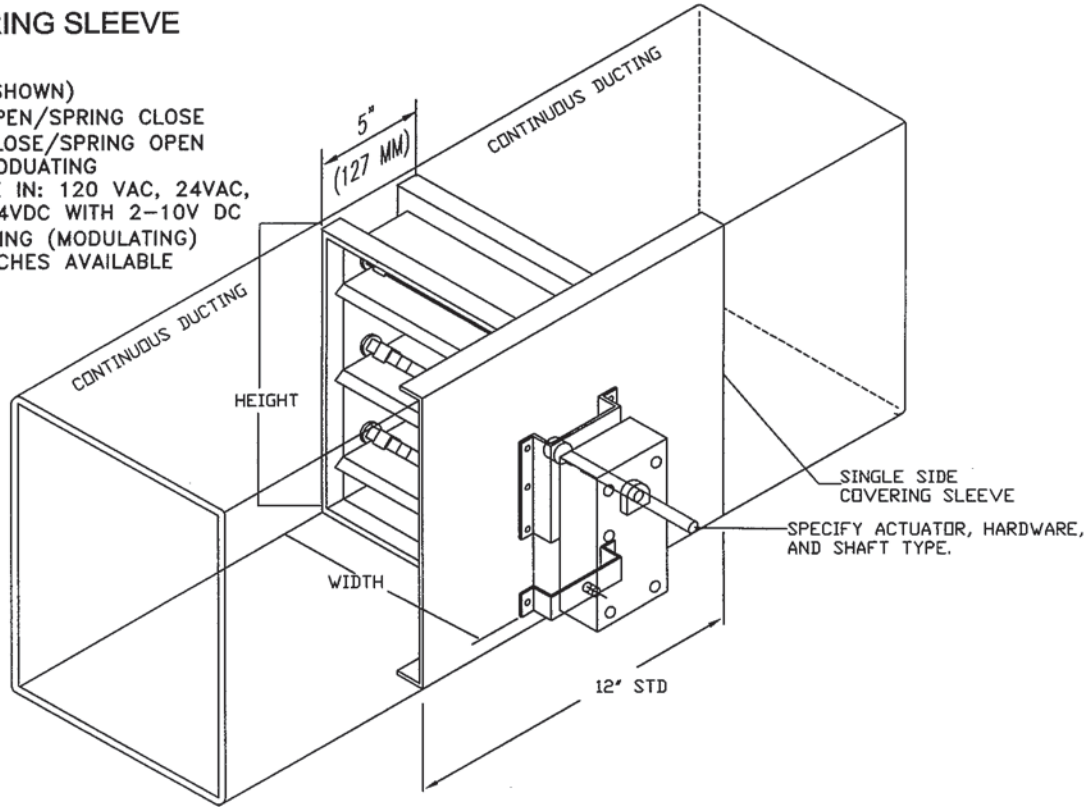

NOTE:
SPECIFY SLEEVE LENGTH AND IF DUCT SIZE IS NOT
IDENTICAL TO DAMPER SIZES.
(ie INSULATED DUCTING)
REFER TO THE ACTUATOR SELECTION INFORMATION FOR
ALL OTHER COMPONENTS REQUIRED.

SINGLE SECTION SIZE AVAILABILITY			MULTIPLE SECTIONS	JOB NAME: _____
	WIDTH X HEIGHT			
MINIMUM	6"	6"	UNLIMITED	LOCATION: _____
MAXIMUM	60"	60"		ARCHITECT: _____
				ENGINEER: _____
				CONTRACTOR: _____

10279-REV-A

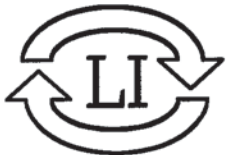

LLLOYD INDUSTRIES INC.

231 COMMERCE DRIVE
MONTGOMERYVILLE, PA. 18936
TEL: 215-412-4445
FAX: 215-412-4409
EMAIL: LLOYDIND@FIREDAMPER.COM

5858 BROADWAY AVE.
JACKSONVILLE, FL. 32254
TEL: 904-378-8440
FAX: 904-378-8441
EMAIL: LLOYDINDI@BELLSOUTH.NET

WEB SITE: FIREDAMPER.COM

AIR CONTROL DAMPER

MODEL AC 10 PARALLEL BLADE
MODEL AC 20 OPPOSED BLADE

LINKAGE MOUNTING
EXTERNAL ACTUATOR
ELECTRIC

BELIMO, LANDIS, HONEYWELL
POWER OPEN/SPRING CLOSE
POWER CLOSE/SPRING OPEN
POWER MODUATING
AVAILABLE IN: 120 VAC, 24VAC,
24VDC, 24VDC WITH 2-10V DC
CONTROLLING (MODULATING)
END SWITCHES AVAILABLE

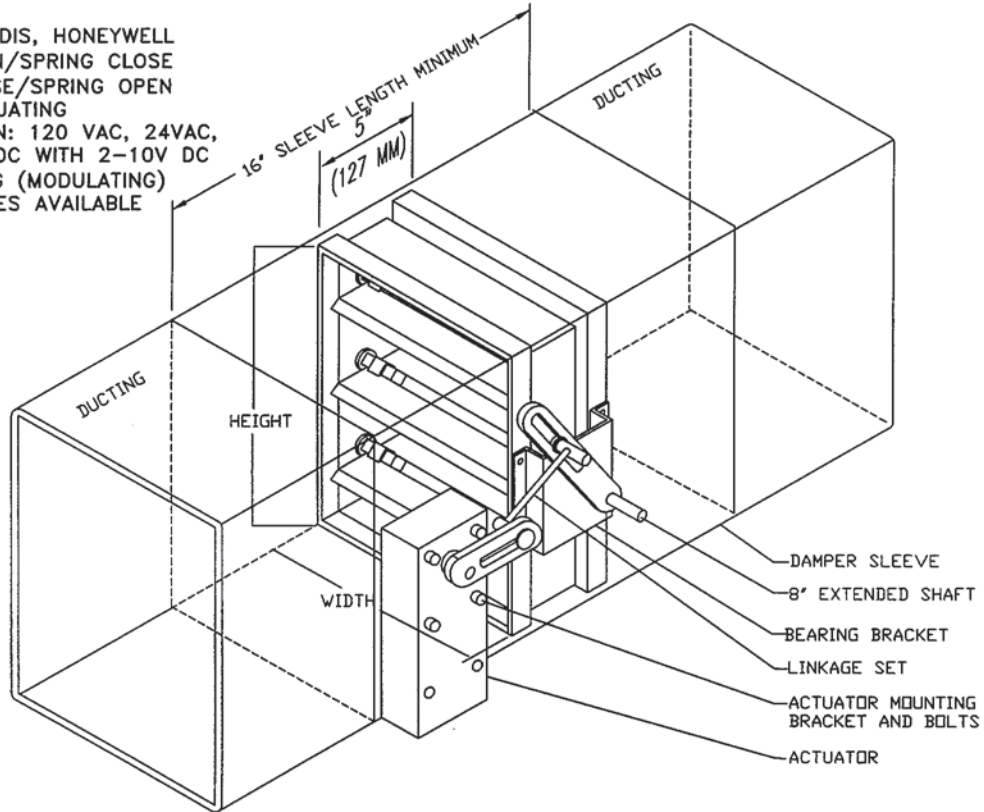

SINGLE SECTION SIZE AVAILABILITY			MULTIPLE SECTIONS	JOB NAME: _____	
	WIDTH X HEIGHT			LOCATION: _____	
MINIMUM	6"	6"	UNLIMITED	ARCHITECT: _____	
MAXIMUM	60"	60"		ENGINEER: _____	
				CONTRACTOR: _____	

10274-REV-A

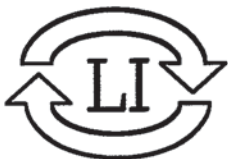

LLOYD INDUSTRIES INC.

231 COMMERCE DRIVE
MONTGOMERYVILLE, PA. 18936
TEL: 215-412-4445
FAX: 215-412-4409
EMAIL: LLOYDIND@FIREDAMPER.COM

5858 BROADWAY AVE.
JACKSONVILLE, FL. 32254
TEL: 904-378-8440
FAX: 904-378-8441
EMAIL: LLOYDINDI@BELLSOUTH.NET

WEB SITE: FIREDAMPER.COM

AIR CONTROL DAMPER

LINKAGE MOUNTING
INTERNAL ACTUATOR
ELECTRIC

MODEL AC 10 PARALLEL BLADE
MODEL AC 20 OPPOSED BLADE

BELIMO, LANDIS, HONEYWELL.
POWER OPEN/SPRING CLOSE
POWER CLOSE/SPRING OPEN
POWER MODUATING
AVAILABLE IN: 120 VAC, 24VAC,
24VDC, 24VDC WITH 2-10V DC
CONTROLLING (MODULATING)
END SWITCHES AVAILABLE

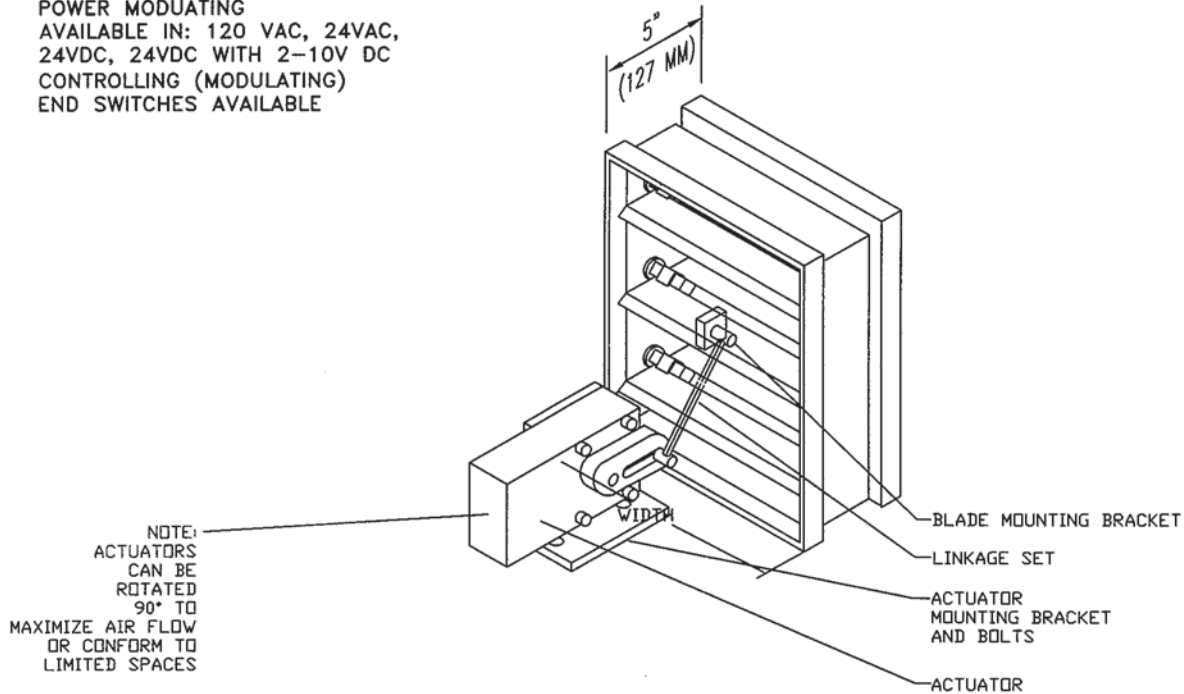

SINGLE SECTION SIZE AVAILABILITY		MULTIPLE SECTIONS		JOB NAME:
MINIMUM	WIDTH X HEIGHT		UNLIMITED	LOCATION: _____
	6"	6"		ARCHITECT: _____
MAXIMUM				ENGINEER: _____
	60"	60"		CONTRACTOR: _____

10275-REV-A

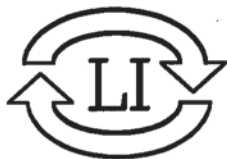

LOYD INDUSTRIES INC.

231 COMMERCE DRIVE
MONTGOMERYVILLE, PA. 18936
TEL: 215-412-4445
FAX: 215-412-4409
EMAIL: LLOYDIND@FIREDAMPER.COM

5858 BROADWAY AVE.
JACKSONVILLE, FL. 32254
TEL: 904-378-8440
FAX: 904-378-8441
EMAIL: LLOYDINDI@BELLSOUTH.NET

WEB SITE: FIREDAMPER.COM

AIR CONTROL DAMPER

LINKAGE MOUNTING
EXTERNAL ACTUATOR
PNEUMATIC

MODEL AC 10 PARALLEL BLADE
MODEL AC 20 OPPOSED BLADE

LANDIS
POWER OPEN/SPRING CLOSE
AND MODULATING
END SWITCHES AVAILABLE

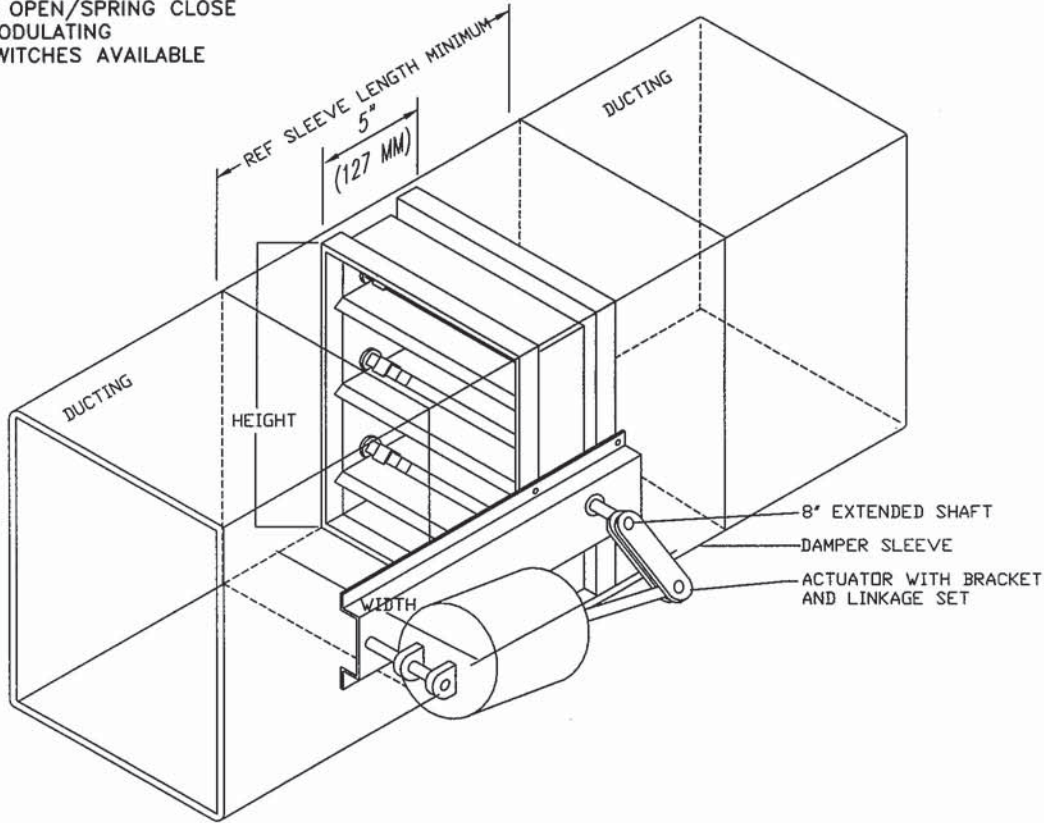

SINGLE SECTION SIZE AVAILABILITY			MULTIPLE SECTIONS	JOB NAME: _____	
	WIDTH X HEIGHT			LOCATION: _____	
MINIMUM	6"	6"	UNLIMITED	ARCHITECT: _____	
MAXIMUM	60"	60"		ENGINEER: _____	
				CONTRACTOR: _____	

10277-REV-A



LLOYD INDUSTRIES INC.

231 COMMERCE DRIVE
MONTGOMERYVILLE, PA. 18936
TEL: 215-412-4445
FAX: 215-412-4409
EMAIL: LLOYDIND@FIREDAMPER.COM

5858 BROADWAY AVE.
JACKSONVILLE, FL. 32254
TEL: 904-378-8440
FAX: 904-378-8441
EMAIL: LLOYDINDI@BELLSOUTH.NET

WEB SITE: FIREDAMPER.COM

AIR CONTROL DAMPER

MODEL AC 10 PARALLEL BLADE
MODEL AC 20 OPPOSED BLADE

LINKAGE MOUNTING
INTERNAL ACTUATOR
PNEUMATIC

LANDIS
POWER OPEN/SPRING CLOSE
AND MODULATING
END SWITCHES AVAILABLE

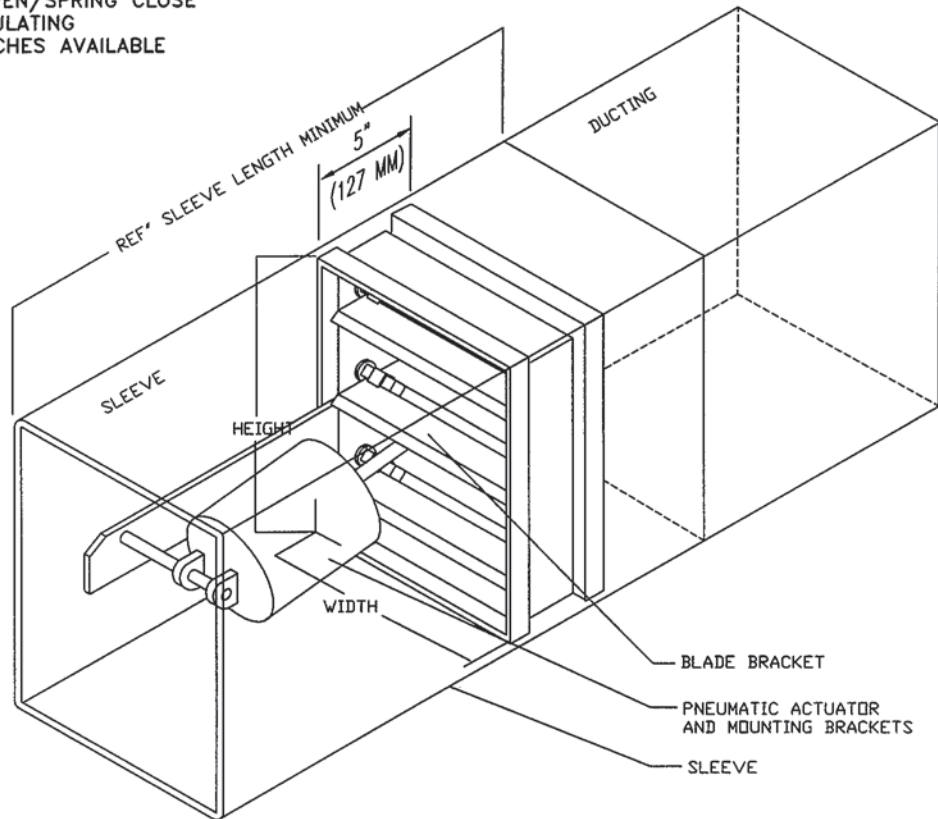

SINGLE SECTION SIZE AVAILABILITY			MULTIPLE SECTIONS	JOB NAME: _____
MINIMUM	WIDTH X HEIGHT		UNLIMITED	LOCATION: _____
	6"	6"		ARCHITECT: _____
MAXIMUM	60"	60"		ENGINEER: _____
				CONTRACTOR: _____

10278-REV-A

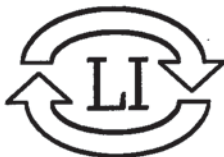

LLOYD INDUSTRIES INC.

231 COMMERCE DRIVE
MONTGOMERYVILLE, PA. 18936
TEL: 215-412-4445
FAX: 215-412-4409
EMAIL: LLOYDIND@FIREDAMPER.COM

5858 BROADWAY AVE.
JACKSONVILLE, FL. 32254
TEL: 904-378-8440
FAX: 904-378-8441
EMAIL: LLOYDINDI@BELLSOUTH.NET

WEB SITE: FIREDAMPER.COM