

## EXTRUDED ALUMINUM LOUVER

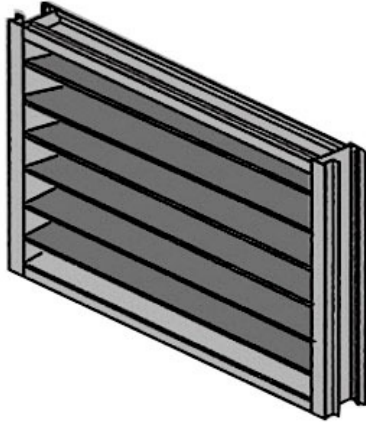

### MODEL: 4-SRCF COMBO COMBINATION INTAKE/EXHAUST

#### APPLICATION

The 4-SRCF COMBO Stationary Louver is 4" deep with a Channel Frame. That is designed for the protection of higher air intake and exhaust velocities in building exterior walls. The louver structure incorporates stationary 36° and 90° blades. The 4-SRCF COMBO is AMCA STD 500 approved

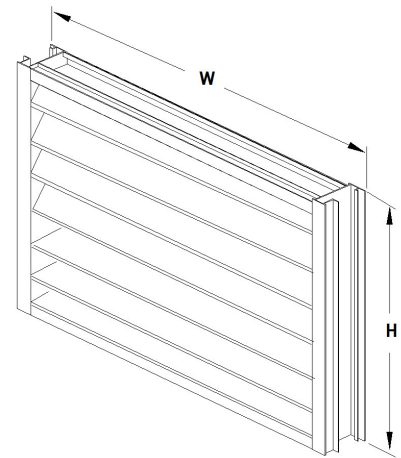

#### SPECIFICATIONS

<b>Frame:</b>	0.081 thick extruded aluminum 6063-T5 mill finish
<b>Blade:</b>	0.081 thick extruded aluminum 6063-T5 mill finish
<b>Blade Spacing:</b>	Approximately 3-1/4" center to center (except at head and sills)
<b>Fasteners:</b>	10" x 3/4" tek screws
<b>Blade Angle:</b>	36° and 90°
<b>Min. Height:</b>	12"
<b>Max. Single Sec.:</b>	Consult factory for maximum size
<b>Screen:</b>	Bird screen 1/2" x 1/2" galvanized steel

#### OPTIONS

Insect Screen 1/16" x 1/16" mesh aluminum  
Bird Screen 1/2" x 1/2" aluminum

Finish: Clear Anodized  
Bronze Anodized  
Powder Coat Paint  
Baked Enamel Paint

