

RETURN & EXHAUST GRILLE

ALUMINUM GRID 1/2" x 1/2" x 1" FOR
SIDEWALL OR CEILING APPLICATION

MINIMUM SIZE: 4" WIDTH x 4" HEIGHT

MAXIMUM SIZE: 48" WIDTH x 96" HEIGHT

EXTRUDED ALUMINUM; 6063-T5

FINISH - SA (CLEAR ANODIZE) OR W (WHITE PAINTED)

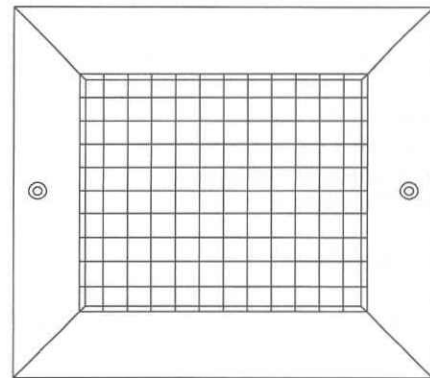

FACE VIEW

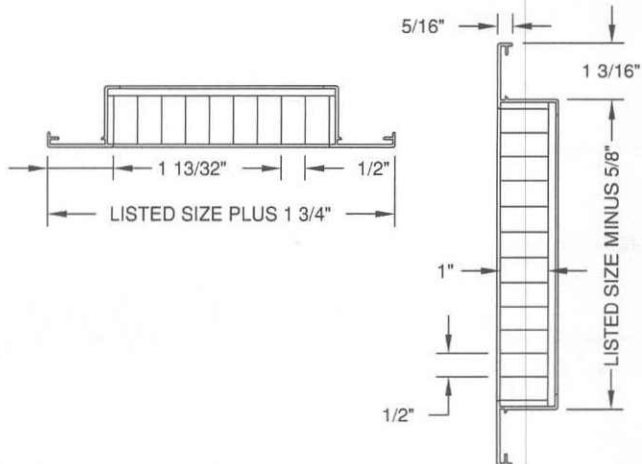

MODEL - GAG-5-1

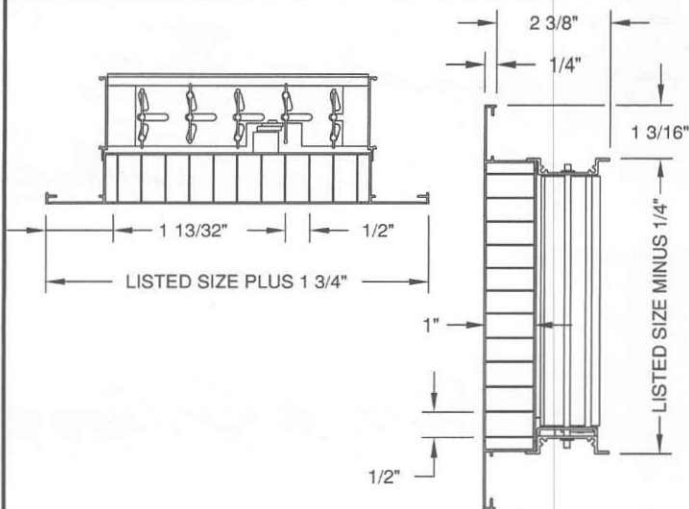

GAG5-1-O - OPPOSED BLADE DAMPER

DWG NO.

02HV045B

DATE:

6/11/02

JOB NAME: _____

LOCATION: _____

ARCHITECT: _____

ENGINEER: _____

CONTRACTOR: _____

FINISH: _____