



MODEL F/S-RD

COMBINATION FIRE/SMOKE DAMPER Installation Instructions

UL File No.
R25410



OPTION 1: ANGLES 2 SIDES

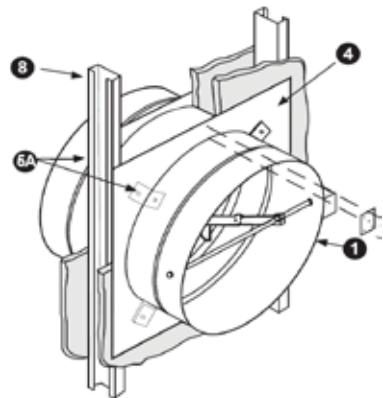

Typical wood, metal stud or masonry opening.
(Refer to Metal or Wood Stud Framing For Fire Dampers In Drywall Partitions)

When UL is referred to in this document, it represents UL/ULC

- 18 gauge galvanized steel integral sleeve shall be of the **SAME GAUGE** or heavier as the duct to which it is attached. Gauges shall conform to SMACNA or ASHRAE duct standards. The length of the sleeve extending beyond the wall opening shall not exceed 16" (406 mm) on the operator side or 6" (152mm) on the opposite side.
- The connecting duct shall terminate at the integral sleeve and is connected by using either:
 - a minimum of 3 - #10 sheet metal screws spaced equidistant around the sleeve for 22" and smaller duct.
 - a minimum of 5 - #10 sheet metal screws spaced equidistant around the sleeve for greater than 22" duct.
 - a 4" (101mm) drawband.

3. Clearance between the damper sleeve and the round or square wall opening shall be a minimum of 1/2" (13 mm) and a maximum of 1" (25 mm).

4. Damper will be factory supplied with one retaining plate secured to the damper sleeve on the operator side of the damper.

5. A minimum of 4 equally spaced 20 gauge galvanized steel clip angles shall be attached to both the integral sleeve and the retaining plate. The clip angles shall be attached with 1/8" (3.2mm) rivets, #10 x 1/2" (12.7mm) steel metal screws, bolts or welds. In metal stud/gypsum applications, the retaining plate may be in front of or behind the gypsum, directly against the metal studs.

6. **Option 1:** The damper may be installed in a wood/gypsum, steel stud/gypsum, or masonry fire partition in the vertical or horizontal position (blade shaft running horizontal) with a retaining plate flush against each side of the fire partition. **Installation:** with the factory installed retaining plate flush to the fire partition, place another retaining plate on the opposite side of the damper sleeve and slide it forward until it becomes flush with the opposite side of the partition. Place the Splice Clip over the cut portion of the retaining plate. Secure it with 4 - #10 sheet metal screws or rivets. Secure the clip angles to the retaining plate and damper sleeve as illustrated.

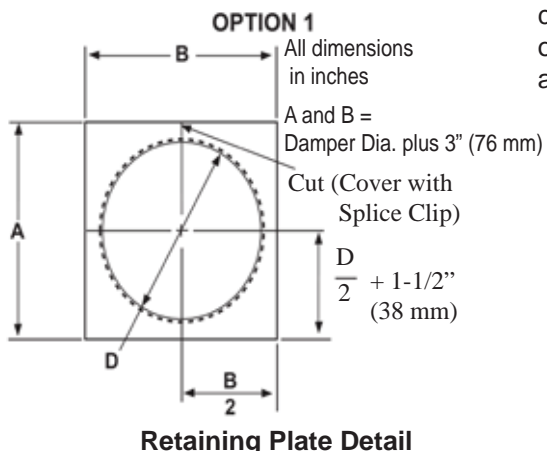
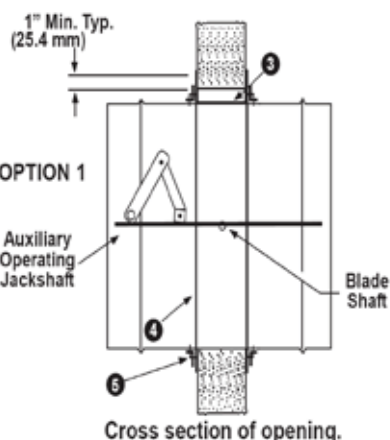

OPTION 1 UL APPROVED WALL OR FLOOR DESIGN

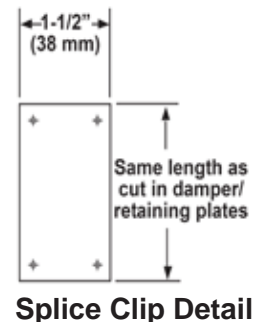
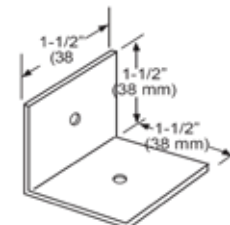
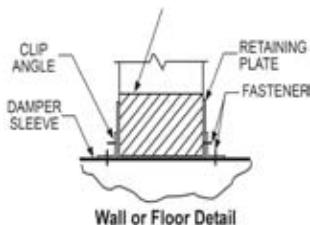

NOTE: CAUTION HEAVY SPRING USED TO LOAD SPRING/LINK ACTUATOR USE CARE IN RESETTING LINK.

IMPORTANT
Do Not Cast Damper In Place
Cycle Damper After Installation To Insure Free Movement
Do Not Install Damper Out Of Round



MODEL F/S-RD

COMBINATION FIRE/SMOKE DAMPER Installation Instructions

UL File No.
R25410

6B. **Option 2:** The damper may also be installed in a steel stud/gypsum, or masonry partition, in a vertical or horizontal (retaining plate on top) position (blade running horizontal), with a retaining plate on one side of the partition. Installation: with the factory installed retaining plate flush to the fire partition, place 8 screws (#10 sheet metal for steel studs long enough to penetrate the metal stud by 1/2" minimum or #10 x 1-1/4" masonry screws) equidistant around the perimeter of the retaining plate. Screws are placed in each corner and halfway between the corners as shown.

7. Electrical and/or pneumatic connections to damper actuators should be made in accordance with wiring and piping diagrams developed in compliance with applicable codes, ordinances and regulations.

8. Refer to the installation instruction for Drywall Type Construction for the material and opening framing details.

9. As with all joints, the contractor must seal duct-collar connections, in the field, after installation.

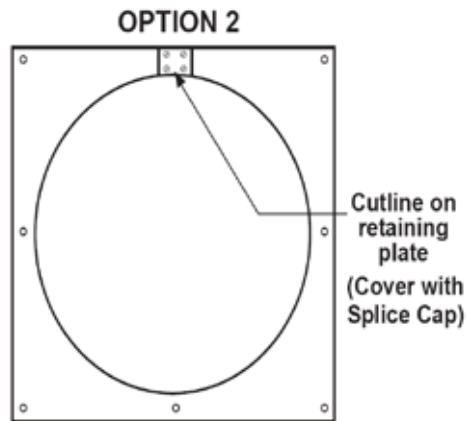

Retaining Plate Detail

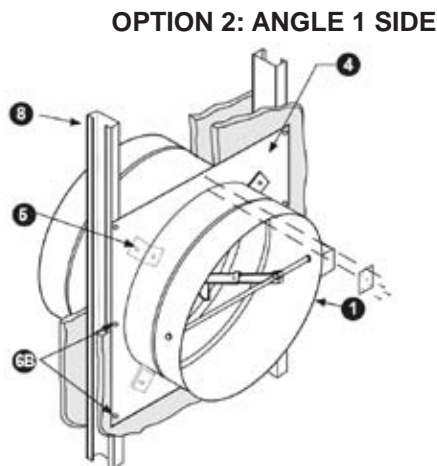

OPTION 2: ANGLE 1 SIDE

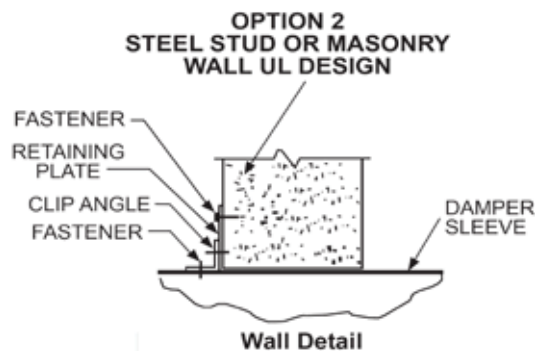

Wall Detail

Typical wood, metal stud or masonry opening.
(Refer to Metal or Wood Stud Framing For Fire Dampers In Drywall Partitions)

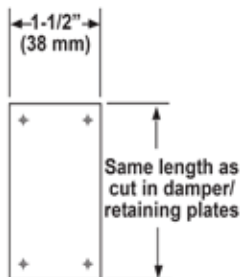

Splice Clip Detail

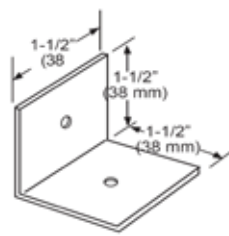

Clip Angle Detail
20 Ga. (1) Galv. Steel

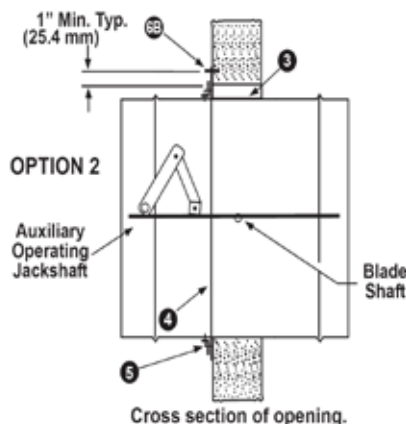

Cross section of opening.

Manufacturer's Recommendations

All moving parts of the damper must be inspected and cycled at intervals not greater than every 12 months or in accordance with the latest edition of NFPA 90A, 92A, local codes and the actuator manufacturer. In addition, fuse links shall be removed and inspected for corrosion. Dry lubricants are recommended.

This installation sheet has been reviewed and accepted by Underwriters Laboratories.

When UL is referred to in this document, it represents UL/ULC.