

Read and Save These Instructions

- Installation by anyone other than a qualified contractor voids the warranty.
- Product designed for residential installation only. Commercial installation voids warranty.
- Modification or alteration of product, parts, installation instructions or local safety codes voids warranty.
 - Read our full warranty policy at the end of this document.



Breathe Healthier

DH70 Table of Contents

Subject	Page #
Specifications	3
Unit Location	3
Electrical Requirements	4
Condensate Removal	4
Ducting	4
Wiring Unit Schematic (Color diagrams provided on unit.)	6
Field Connections, Low Voltage	7
Typical Equipment Layout Specification & Duct Connection	7
Operation	7
Typical System Operation Sequence	8
Coil Freeze Protection (Auto Defrost)	8
Maintenance	8
Trouble Shooting	9
FAQ's	10
Warranty Registration	11
Limited Warranty	11-12

**WARNING!**

This symbol indicates: **IMPORTANT INSTRUCTIONS!**

Failure to heed them can result in serious injury or death.

**CAUTION!**

This symbol indicates: **IMPORTANT INSTRUCTIONS!**

Failure to heed them can result in serious injury or material property damage.

Specifications

- Capacity: 70 pints/day, (3.25 lbs./hr.) @ 80°F/60%RH
- Ideal in Crawl space, attic or basement.
- Electrical: 110-120 VAC, 6.7 FLA Amps, 60 Hz, grounded
- Operating Return Air Temp. Range: 50°F min., 90°F max.
- Air Flow:
 - 280 CFM without external ducting
 - 235 CFM @ .30 IWG external static
 - 195 CFM @ .50 IWG external static
- Refrigerant Charge: 17.5 oz. R-410A
- Duct connections: Return duct flange: 8" Round, Outlet 8" Round,
- Filter Size: High Efficiency (MERV 11): Pleated 11-3/4" X 11-3/4" X 2"
- Size (Clearance): 14" Height x 26" Width x 14" Depth, 12" minimum front or rear clearance for filter service.
- Weight: 65 pounds (Shipping Weight 73 pounds)



Unit Location

The DH70 can be installed in a variety of locations to meet the owner's needs as listed below. In all cases keep the following cautions in mind:

- The unit is designed to be installed indoors in a space that is protected from rain, flooding and/or other forms of excess water. Unit is not designed to be exposed to chlorinated pool conditions or spaces where unit will be exposed to corrosive chemicals or conditions. **DO NOT LIFT OR MOVE THE UNIT BY GRASPING THE DRAIN HOLE, AS IT MAY CAUSE DAMAGE TO THE DRAIN PAN.**
- Install the unit with space to access the front panel for maintenance and service. Also allow easy access to the filter cover panel. **CAUTION: DO NOT INSTALL THE UNIT WITH THE FRONT PANEL OR FILTER COVER PANEL INACCESSIBLE. DAMAGE TO THE DRAIN PAN CAN OCCUR.**
- Avoid discharging the air directly at people, or other areas or objects where dehydration or evaporation of moisture is not desired.

WARNING: If used near wet areas, be certain there is NO chance the unit could fall into the water or be splashed and that it is wired into a **GROUND FAULT INTERRUPTER** protected circuit (see local codes for other requirements).

CAUTION: A secondary drain pan **MUST** be placed under the unit if installed above a living area or above an area where water leakage could cause damage (see local codes for other requirements).

- **DO NOT** locate the DH70 directly on structural members where noise or vibration may be objectionable. The DH70 is equipped with adjustable support feet to raise and level the unit from the mounting surface. Ensure unit is installed level using the included bullseye level.
- In a whole house system, the DH70 should be located near the existing air handling system to minimize the required duct work for connecting of the DH70 system. When the remote control option is used, the control (humidistat) unit must be located in the space that is to be conditioned. The control (humidistat) may be low voltage (24 volt) and should be connected to the DH70 with code approved, low voltage thermostat cable.

• **When a remote Humidistat is utilized, set the unit mounted humidistat to the "OFF" position.**

- When locating the DH70 in areas of extreme heat or high humidity, >120-degrees/90% humidity, additional external insulation may be required to prevent undesired condensation on the exterior of the unit.

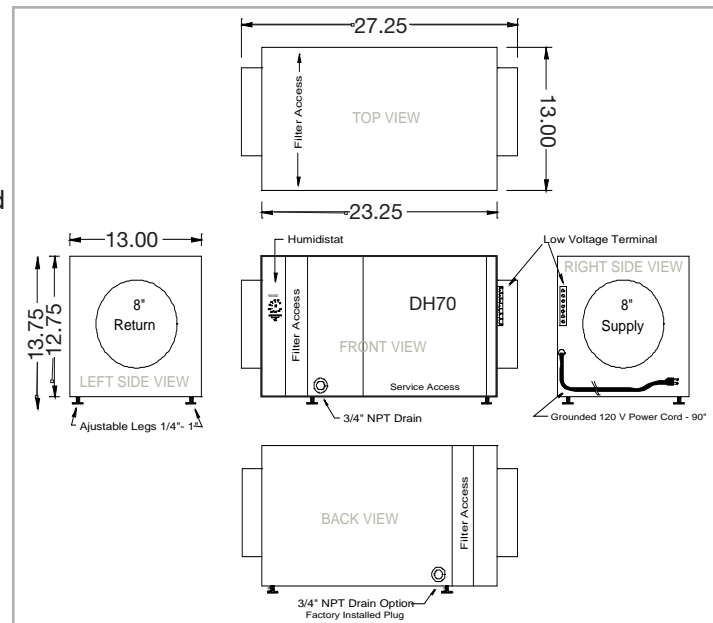

⚠ Electrical Requirements

⚠ WARNING: Disconnect power before installation and / or servicing, as electric shock may occur and cause serious injury or death.

⚠ WARNING: The DH70 is equipped with a power cord with ground prong and may be plugged directly into a grounded 3 prong, 120 volt, 15 amp household type convenience outlet. If used in a wet area such as an area prone to flooding (basement or crawl space), **a ground fault interrupter protected circuit is required.** In all cases local codes precede over all installation and wiring recommendations.

- **Do not remove ground prong. Do not use an adaptor. Do not use an extension cord.**
- If a remote wall mounted Humidistat is utilized, install the Humidistat control in a central area of the structure where it will sense the relative humidity of the structure accurately. Do not install the control where it may not accurately sense the relative humidity: near HVAC supply registers, or near exterior doors. Do not install the control in an area not served by the DH70. The installer must supply the wiring between the DH70 and the Humidistat control. Be sure to safely route the control wiring to prevent damage during installation. Be careful not to cross the wires when connecting the DH70 and the control or damage to the transformer may result.
- **When a remote Humidistat is utilized, set the unit mounted humidistat to the “OFF” position.**
- Consult the electrical schematic (Page 6 in this manual) or inside the access panel of the DH70 before making the control connections.

Condensate Removal

- Condensate drains by gravity, via the ¾” PVC drain outlet located at two locations, front side and back side. Use of both is not required.
- As shipped the rear drain is plugged, and may be removed and replaced into the front drain outlet if the rear outlet is used.

⚠ CAUTION: Also included with the unit is the condensate drain trap, **which must be used to allow the unit to drain properly during operation and prevent air from being drawn from the area where the unit is located.**

- An optional condensate pump kit may be installed if a lift is required to dispose of the condensate.
- **If an optional pump is used the condensate trap is still necessary and must be installed between the unit and pump.**
- When the condensate drain is located in, or passes through, a non-conditioned space, **the condensate piping should be insulated to prevent the drain line sweating that may cause damage.**

⚠ CAUTION: Avoid double trapping. Where flexible tubing is used, or the possibilities of sags occurring in the drain line exist, or the drain terminates in a sump below the waterline, the drain must be vented to allow proper draining. A condensate drain vent must be installed at the outlet side of the drain trap, between the trap and the balance of drain line.

Ducting (See Duct Connection Diagram, Page 7)

A. Installing Duct

The DH70 is equipped with an 8” round duct collar inlet, and an 8” round exhaust/supply collar that provides for connecting to the supply distribution system. In all cases sound duct design practices must be followed such as those provided in ACCA manual “D”, or ASHRAE’s “Fundamentals of Air System Design”.

B. Ducting for Dehumidification

For the ideal installation, draw air from the central part of the home and return it to the isolated areas of the home like the bedrooms, den, utility room, or family room. The duct work of the existing HVAC system can be used to supply air to the home. If the existing supply duct adequately serves all areas of the home, discharge the supply air of the DH70 into the return of the existing HVAC system where it can be distributed throughout the space. The existing return duct, if adequate, may be used as return for the DH70. **DO NOT** draw air directly from the kitchen, laundry, bathroom, or isolated basement. You may draw air from a basement that is open to the home. All flexible ducting connected to the DH70 should be approved by local codes and in most cases insulated.

- Return air ducts should be designed to allow unimpeded air flow to the return side of the system. For returns less than 10' in length, an 8" round or equal may be utilized. Multiple returns are acceptable.
- The supply air outlet and the return air inlet are located on each end of the DH70. A length of acoustical flex ducting on the outlet of the DH70 will reduce air noise. A length of flexible ducting on all DH70 duct connections is recommended to reduce noise and vibration transmitted to rigid duct work in the structure.
- Ducting the DH70 as mentioned in the "Ducting" sections requires consideration of the following points:
 - **Duct Sizing:** For total duct lengths up to 10', use a minimum 8" diameter round or equivalent rectangular. For longer lengths, up to 25', use a minimum 10" diameter or equivalent duct size. Grills or diffusers utilized must not excessively restrict airflow.
 - **Isolated Areas:** Effective dehumidification may require that ducting be branched to isolated, stagnant areas. Use 8" or larger diameter branch ducting to each of two or three areas, use 6" or larger to each of four or more areas.
 - **Connecting to Existing HVAC Systems:** For proper operation, connecting to existing air handler and duct systems requires the fans of each system to be interlocked utilizing the low voltage interlock method provided in the DH70 low voltage connection diagram. Refer to low voltage connection diagram in this document and on the unit.

C. Installation in Basement or Crawl Space with Existing Forced-Air HVAC System (WH)

If the structure in which the DH70 System is to be installed has an existing forced-air HVAC system, and this system serves the areas that are desired to be controlled, utilize the HVAC system to make the DH70 System installation easier and provide better whole house type system performance.

Basement or Crawl Space Installation: Install a separate 8" return for the DH70 in a central area of the structure or if the return ducting is adequate tap into the existing return duct system near the return air grill. Duct the supply of the DH70 System to the return ducting of the existing HVAC system. The fan interlock provision must be utilized for proper system performance.

D. Installation in Attic with an Existing Forced-Air HVAC System (WH)

IMPORTANT: A secondary drain pan **MUST** be installed with a drain or float interrupt for condensation under the DH70 in an attic to prevent condensate overflow that may drip down damaging the ceiling or living space below.

Install a separate 8" return for the DH70 in a central area of the structure or if the return ducting is adequate tap into the existing return duct system near the return air grill. Duct the supply of the DH70 System to the return ducting of the existing HVAC system. The fan interlock provision must be utilized for proper system performance.

E. Installation in Structure with Two Forced-Air HVAC Systems (WH)

Attach the DH70 return to an independent return from the upper level. Attach the DH70 supply to the return of the basement HVAC system. This will promote circulation of air through the whole structure from the upper level to the lower level through the DH70. If the DH70 is not connected to both HVAC systems, it may not control the humidity of the entire structure. The fan interlock provision should be connected to the lower ducted HVAC system and must be utilized for proper system performance.

- **WH = Whole House Dehumidification**
- **SP = Spot Dehumidification**

F. Installation in Structure with No Existing Forced-Air HVAC System (WH)

When installing the DH70 in a structure that does not have a forced-air HVAC system, a single return for the DH70 should be installed in central open area of the structure. **DO NOT** locate the return in a bathroom or a kitchen. The supply of the DH70 should be located in the remote areas of the structure (such as bedrooms, den, etc.). By ducting this way, the air inside the structure will circulate through the DH70 to be filtered and dehumidified. 5" diameter duct is recommended for branches to the bedrooms, 6" diameter duct is recommended for branches to larger areas.

G. Installation in Sealed Crawl Space or Sealed Attic (SD)

When installing the DH70 in sealed crawl space or sealed attic, a single return for the DH70 should be installed in central open area of the structure. If the area is open without partitions return ducting is not necessary. Supply ducting is recommended to enhance the performance of the system, a minimum length of supply duct, 3' to 6' will aid in air distribution. If the area(s) being served are divided by walls or partitions, a supply and return duct system is recommended. In all cases sound duct design practices must be followed such as those provided in ACCA manual "D", or ASHRAE's "Fundamentals of Air System Design".

Wiring Unit Schematic (Color diagrams provided on unit.)

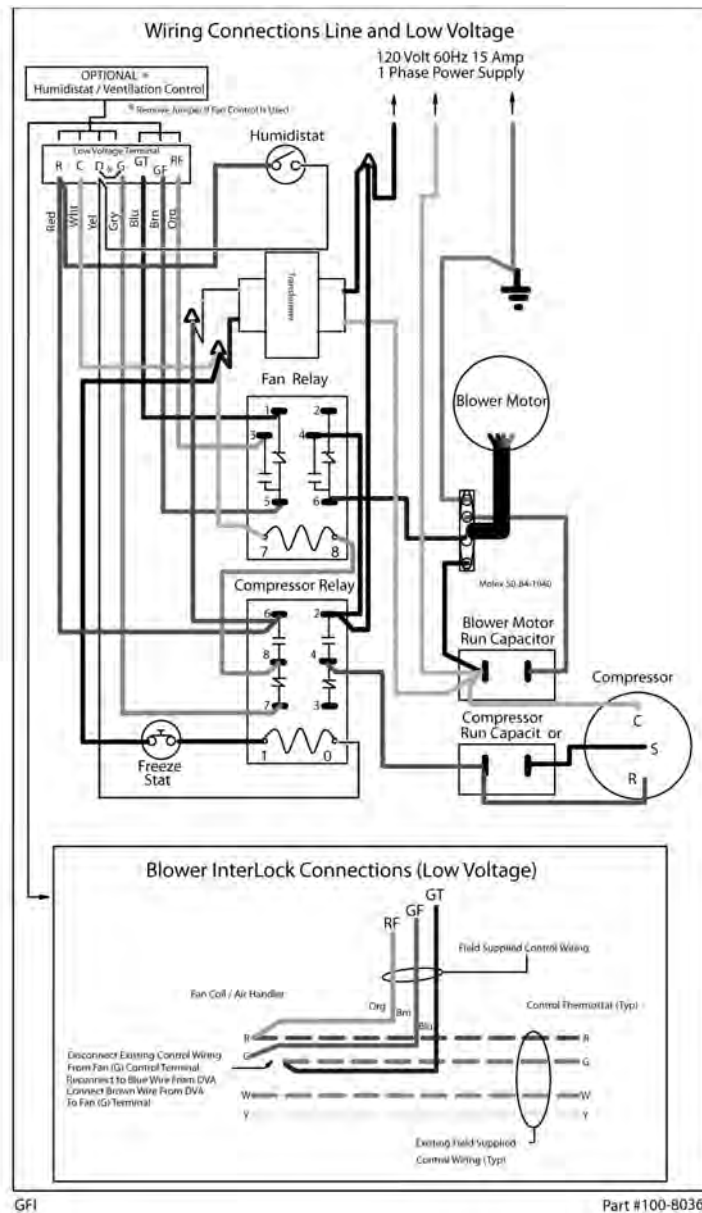

- WH = Whole House Dehumidification
- SP = Spot Dehumidification

Field Connections, Low Voltage

When a remote Humidistat is utilized, set the unit mounted humidistat to the “OFF” position.

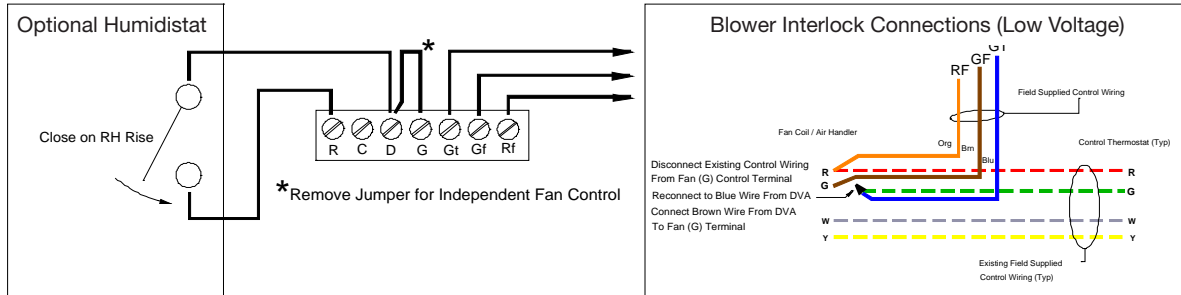

Typical Equipment Layout Specification & Duct Connection Diagram

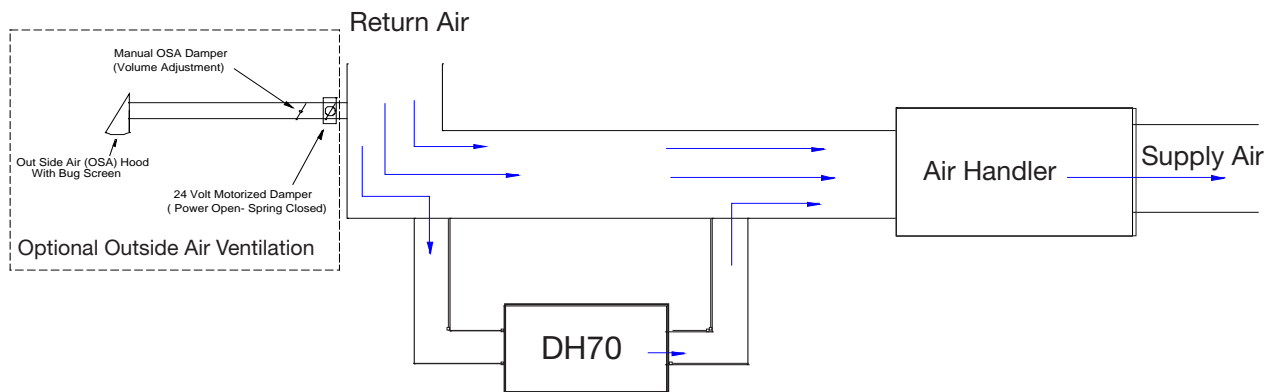

Operation

The DH70 is designed to deliver dehumidified, filtered air to the living space. It is equipped with an onboard humidistat and fan control, and can be equipped with various accessories to enhance its operation (including a remote humidistat).

Research shows that a relative humidity level of 40% to 60% is ideal indoors; however, other factors may dictate a relative humidity level different than the recommended (examples: the presence of musical instruments, antiques or artwork; remodeling projects; extensive woodwork; personal reference). Winter minimum humidity levels of 30-35% may not be attainable without supplemental humidification (humidifier), and may not be desired during times of low outdoor temperatures.

System Variations:

The system may be installed as a free standing unit, or incorporated with a home's heating / cooling /HVAC system.

Unit Humidity Control - Standard

Change the humidity set point on the DH70 by rotating the dial shaft (built into the unit) so that the flat side of the dial shaft faces the desired set point (See figure 5.0 to right).

Remote Humidity Control (Wall Mounted Dehumidistat)

When a remote Dehumidistat is utilized, set the unit mounted humidistat to the “OFF” position.

This control provides the same control functions as above but with greater precision, can be located in the space for easier access, and may include additional features. Available as an accessory item these controls may have different features. Refer to instructions included with the control.

Flat Side of Dial Shaft (Dark Half in Photo at Right) Pointing to 45%

Figure 5.0



Typical System Operation Sequence

When the relative humidity exceeds the humidistat set point, the humidistat will energize the dehumidification and air circulation components of the DH70 (note the time delay on some electronic humidistats). If the DH70 system is connected and interlocked with an existing Heating/Air conditioning system, the system circulation fan will also be energized. The DH70 will continue to operate until the humidity level is reduced to the set point selected on the humidistat and then will cycle off. During this cycle, the air circulated through the DH70 system will be filtered and dehumidified.

Coil Freeze Protection (Auto Defrost)

The dehumidification coil (evaporator) is equipped with a low temperature freeze thermostat; if the coil temperature is reduced to the point of ice buildup, this thermostat will open the compressor control circuit while allowing the fan to continue running. Once the coil has returned to normal conditions the control will close and allow the compressor to re-start. The prevailing conditions of the return air, temperature and humidity, will determine the length of this cycle.

Maintenance

High Efficiency Air Filter - Replace a *Minimum* of Once Per Year

The DH70 includes a MERV 11 pleated filter that captures as much as 80% of particles 1.0 to 3.0 microns in size. The filter's function is to keep your dehumidifier running clean and efficient (whether incorporated into your HVAC system or installed as a stand alone unit in a basement, crawl space or attic). The MERV 11 air filter is NOT designed to replace your current whole house air cleaner/filter installed within your HVAC system.

Operating the unit with a dirty filter will reduce dehumidifier capacity and efficiency, may cause the compressor to cycle off and on unnecessarily, and may clog the heat exchange coils. Under normal operating conditions, the filter will last approximately 3 to 6 months. However, in high particulate concentrations more frequent replacements may be required.

It is recommended that the filter be inspected regularly for the first three to four months to determine the loading and correct replacement intervals. Your installation contractor should be contacted for assistance. **Replace your filter a *minimum* of once per year, or as often as required to keep unit clean, to maintain your warranty.**

To access the air filter, remove the filter access panel from the front or back side of the unit, marked "Filter Access". The filter should be readily visible and can be removed by pulling it straight out of the unit. Ensure arrows indicating air flow direction are pointed towards the unit. (Watch video on www.generalfilters.com/Support Center/Video Library for a demonstration.) Replacement filters can be purchased from your installing contractor or ordered from the factory if a local representative is not available.



DO NOT operate the unit without the filter, or with a less effective filter than originally supplied. **FAILURE TO MAINTAIN SERVICE AND UTILIZE CLEAN FILTERS WILL VOID WARRANTY.**

Oiling & Lubrication

The fan motor is factory lubricated and sealed, and no further oiling is required. There are no other components requiring the addition of lubricants.

Trouble Shooting

1. My dehumidifier won't run.

Check for the following:

- Verify there is power to the unit.
- Check that any disconnect switch is in the ON position.
- Check that the circuit breaker is not tripped (a separate 15 amp circuit breaker is recommended).
- Verify the dehumidistat is not turned to OFF.
- Verify low voltage wiring between heating and air conditioning system and dehumidifier is correct.

2. The dehumidifier runs continually but doesn't seem to remove moisture / does not "dehumidify".

Check for the following:

- The filter may be dirty. Check and clean if necessary.
- The dehumidistat may be set at an unrealistically low setting. Reset it to approximately 50% RH.
- Temperatures below 60° or average of 50% RH can cause poor or no production.
- If you've just begun using your dehumidifier, give it a little more time.

3. Water drips from my unit.

Check for the following:

- Ensure the unit is level.
- Verify condensate drain is properly trapped.
- Check for a plugged condensate trap or condensate line.
- Checked for a blocked filter or iced coil.

4. My dehumidifier removes some water, but not as much as expected.

The following might be occurring:

- The air temperature or humidity has dropped.
- The air filter may be dirty or airflow is restricted. Check both and clean / remove obstruction.
- The dehumidifier coils might be dirty.
- There may be air leaks, such as a loose cover or panel; or leaks in the duct work.

*For your safety, contact a licensed contractor when repair involves access to the interior of the unit.
(This includes accessing items such as the compressor, motor, etc.)*

FAQ's

1. Does the dehumidifier require any maintenance?

Yes. It is recommended that the filter be inspected regularly for the first three to four months to determine the loading and correct replacement intervals. Your installation contractor should be contacted for assistance.

Replace your filter a *minimum* of once per year, or as often as required to keep unit clean, to maintain your warranty.

2. Other than dehumidification, what is the benefit of running the dehumidifier in a basement?

Because the air coming from the dehumidifier is slightly warmer than the room temperature, there can be a slight warming effect in the basement. This will further assist in lowering the Rh of the basement, as the same air at higher temperatures has a lower Rh. Dehumidification can also reduce pest populations attracted to moisture.

3. How does the dehumidifier know it needs to remove moisture?

The unit cycles on the dehumidistat setpoint. When humidity reaches setpoint on humidistat, the unit will turn on to remove humidity.

4. What are my installation options?

The DH Model Dehumidifiers have been specially designed for small spaces such as basements, crawl spaces and attics, so they fit many installation circumstances. Each come with adjustable feet that allow for level installations even if the floor is not level. You can even suspended them from the ceiling (with optional accessories).

5. How can a dehumidifier reduce the dust mite population in my home?

Dust mites are the most common allergen-producing organism found in homes. They live in carpets, upholstered furniture, bed pillows and mattresses. If the relative humidity in your home is below 50%, dust mites desiccate. If the relative humidity rises above 50% they thrive and reproduce, their appetite increases, and therefore their fecal matter (the source of the dominant dust mite allergen) increases. Ninety percent of the population that experiences any allergy-based symptoms reacts to dust mite allergen.

The best solution is to control the relative humidity in your home. Dust mites can not survive in areas where the humidity level is below 50%. Have the relative humidity checked in your home during summer and fall. Relative humidity can be controlled by the use of a whole-house dehumidifier installed adjacent to the air conditioner. By controlling the humidity, you completely remedy the dust mite problem.

- Genus: Dermatophagoides; Mites are Arachnids (members of the spider family)
- Species: Dermatophagoides Farinae (DF) - commonly found in North America
- Size: About 250 to 300 microns (μm) in length
- Adult Mite Lifespan: Up to 3 months; (3 larval stages)
- Reproduction: Female mites lay about 25 to 50 eggs
- Habitat: Mites live in carpet, fabric upholstery, and mattresses.
- Diet: Human skin scale, animal dander and trace nutrients.
- Mites need to absorb humidity, they cannot drink water.
- Allergen: Dust mite fecal material.
- Average Threshold before Developing Allergies: 100 mites/gm of dust
- Living Conditions: Temp. Range: approx. 59°F to 95° F (15°C to 35°C)

Warranty Registration - Keep a Copy For Your Records



Product Information

Serial Number: _____
 Model: _____
 Installation Date Month: _____ Day: _____ Year: _____

Owner Information

Name: _____
 Address: _____
 Address 2: _____
 City: _____ State: _____ Zip Code: _____
 Phone: _____
 Email: _____

Contractor Information

Contractor Name: _____
 Address: _____
 Address 2: _____
 City: _____ State: _____ Zip Code: _____
 Contractor Phone: _____
 Contractor Email: _____



Register Online

www.GeneralAire.com / Support Center

Or Mail

USA CUSTOMERS, MAIL TO:

General Filters, Inc
 Attn: Warranty Dept.
 43800 Grand River Ave.
 Novi, MI 48375
www.generalfilters.com

CANADIAN CUSTOMERS, MAIL TO:

Canadian General Filters, Ltd.
 Attn: Warranty Dept.
 400 Midwest Rd.
 Toronto, ON M1P3A9 Canada
www.cgfproducts.com

Keep a copy for your records!

Limited Warranty

What is Covered

- Two Years: DH70 Parts are warranted by General Filters, Inc. ("Company") for a period of two (2) years from the date of the original installation, when installed in residential applications only ("Limited Warranty Period").
- Five Years: DH70 Compressor is warranted for five (5) years from the date of the original installation in all residential applications ("Extended Warranty Period").
- This Limited Warranty runs to the original purchaser of the Product(s) who owns, and resides in, the residential property for which it is installed and maintained.
- The Limited Warranty coverage begins upon the date the Product(s) is installed.
- This Limited Warranty is valid only for the original customer purchasing from Company, and is not transferable.

What is Not Covered

- The following components are not covered by this warranty: cabinets, cabinet pieces, air filters, driers, refrigerant, refrigerant line sets, wiring, fuses, and unit accessories.
- Installation by anyone other than a qualified contractor voids the warranty.
- This product is designed for residential installation only, therefore, commercial or industrial installations are not covered under this warranty.
- Failure to install the DH70 in accordance with these instructions, local codes or ordinances voids the warranty.
- Modifications, changes or alterations to equipment.
- Failure to perform regular maintenance as described in this document voids the warranty.
- This Limited Warranty is valid only for the original customer purchasing from Company, and is not transferable.
- Damage caused by misuse, neglect, fire, wind, mold, damage in transit, or other casualty, contact with corrosive materials (chlorine, fluorine, salt, urine, fertilizers, recycled waste water, or other damaging substances), damage caused during installation, or any cause beyond General Filters, Inc. control is not covered under this Limited Warranty.
- Labor involved in diagnostic calls or in removing, repairing, servicing or replacing parts is not covered under this Limited Warranty.
- Use of contaminated or alternate refrigerant.
- Shipping charges are not covered by this Limited Warranty.
- Agreements made by third parties that are not listed in this Limited Warranty.



What is Not Covered, Cont.

- Liability for special, incidental, direct, indirect, collateral and consequential damages is excluded. Some states do not allow limitation of incidental damages, so the limitations or exclusions may not apply to you. General Filters, Inc. will not pay electricity or fuel costs, or increases in electricity or fuel costs, for any reason whatsoever, including additional or unusual use of supplemental electric heat. This warranty does not cover lodging expenses or labor charges. General Filters, Inc. shall not be liable for any default or delay in performance under this warranty caused by any contingency beyond its control. This warranty gives you specific legal rights, and you may also have other rights which vary from state to state.

Limitations Of Liability

- General Filters, Inc. makes no express warranties other than the warranty specified above.
- The implied warranties of merchantability and fitness for a particular purpose are limited to the duration listed.
- The manufacturer assumes no liability in connection with the installation or use of the product, except as stated in this Limited Warranty.
- The manufacturer will in no event be liable for incidental or consequential damages.
- This limited warranty gives you specific legal rights, and you may also have other rights which vary from state to state. Some states do not allow either limitations on implied warranties, or exclusions from incidental or consequential damages, so the above exclusion and limitation may not apply to you.

Questions

- Any questions pertaining to this limited warranty should be addressed to the manufacturer. (U.S.A.: The manufacturer has elected not to make available the informal dispute settlement mechanism which is specified in the Magnuson-Moss Warranty Act.)

To Make a Warranty Claim / Obtain Service

- Owner must submit a warranty registration within 30 days after installation of Product(s) (See last page for instructions).
- The Owner must complete our online Return Merchandise Authorization (RMA) Form (www.generalfilters.com/returns), to arrange for applicable Limited Warranty service, within the warranty period. Owner must also provide complete model and serial number, proof of required periodic maintenance, installation date and location and an accurate, detailed description of the problem.
- Owner shall be solely responsible for properly packaging the Covered or Extended Coverage Equipment, for all freight charges, and for all risk of loss associated with shipment.
- Owner is responsible for obtaining a licensed contractor to perform any repairs, maintenance or other work on unit.
- If during the Limited or Extended Warranty Period, Covered or Extended Coverage Equipment fails because of a manufacturing defect, Company will provide a free replacement part to the Owner through a licensed service contractor.