



MODEL 2000

LINEAR BAR GRILLES/REGISTERS - OPTIONS
EXTRUDED ALUMINUM - 1" BORDER 1/2" CENTER

Project: _____
 Tag: _____
 Engineer: _____
 Contractor: _____
 Date: _____

MODELS

- 2000:** Wall Mounting - 7/32" Bars - 0° Deflection
- 2000H:** Concealed Mount Hanger - 7/32" Bars - 0° Def.
- 2000F:** Floor/Sill/Wall Mount - 7/32" Bars - 0° Def.

- 2015:** Wall Mounting - 7/32" Bars - 15° Deflection
- 2015H:** Concealed Mount Hanger - 7/32" Bars - 15° Def.

2000 & 2015 (Wall Mounting)

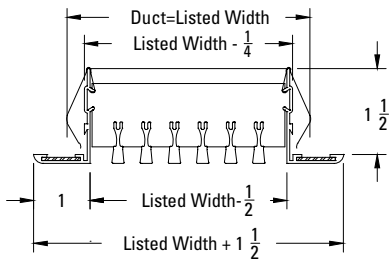

2000H & 2015H (Concealed Mounting Hanger)

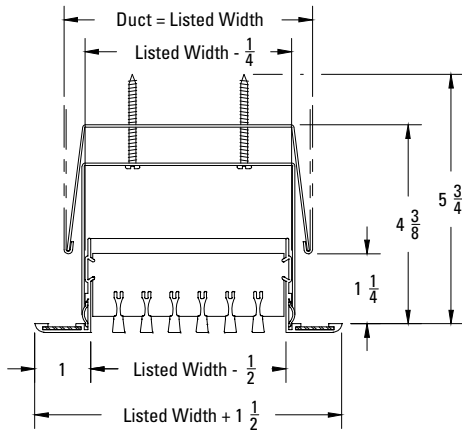

2000F (Floor/Wall/Sill Mounting)

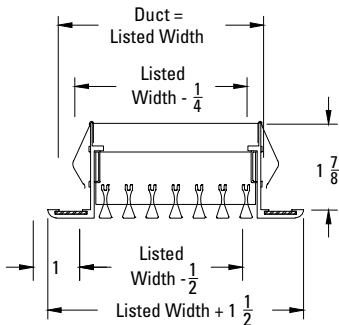

Face View

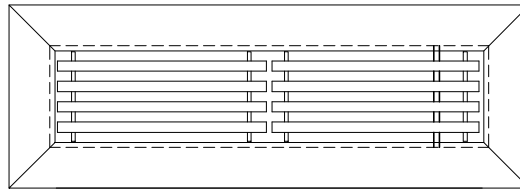

Side View (2000 & 2015)

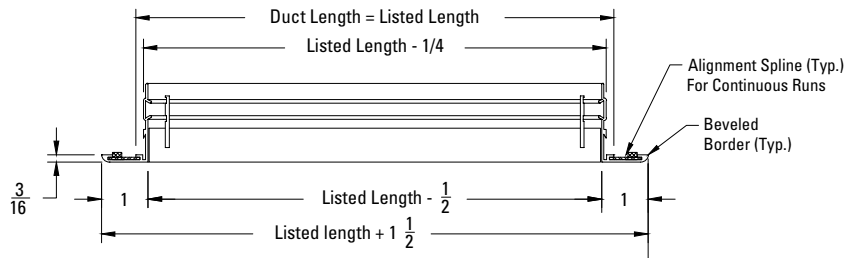

Side View (2000H & 2015H)

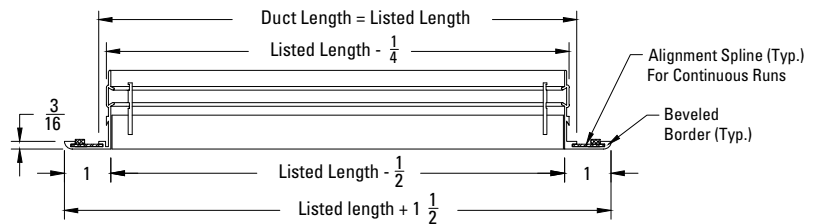

Side View (2000F)

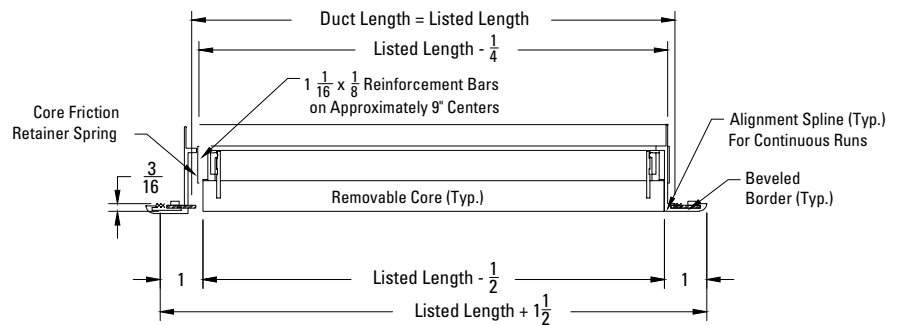

All Dimensions are in Inches.

As part of our continuous improvement program, we reserve the right to make further improvements without notice.

Submittal - 2000 - 0320



WebREPS
800-810-3280

OPTIONS

Option: DA Damper (2000 & 2015)

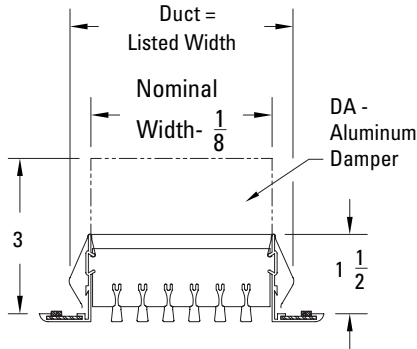

Option: DA Damper (2000 F)

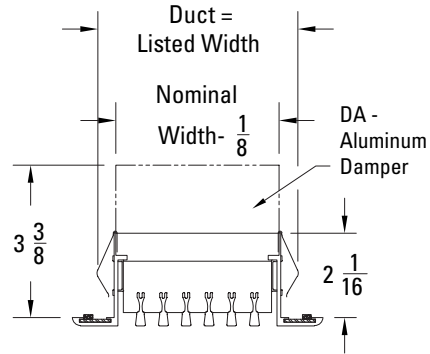

Option: DA Damper (2000 H & 2015 H)

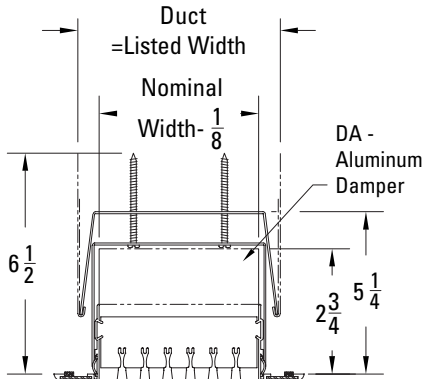

Option: 0° or 15° Deflection

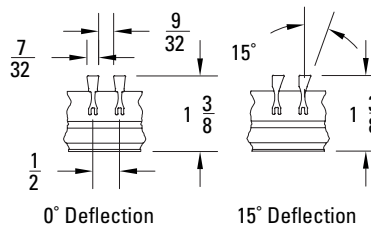

All Dimensions are in Inches.

| 1. Available Finishes | 2. Available Accessories | 3. Available Options | 4. Construction Details |
|---|---|---|--|
| <p>Standard Finish: 01 White</p> <p>Optional Finish (no extra charge): 24 Mill Finish</p> | <p>DA - Aluminum Damper If selected</p> | <p>Dampers: Widths 3-1/2" and smaller use a single flap style damper. Widths 4" and larger use: FSM - Face Screw Mount DA - Damper Model</p> | <ul style="list-style-type: none"> • Widths avail. in 1/2" increments from 1-1/2" to 24". • Lengths avail. in single pieces up to 72". • Longer sections are made by joining sections in the field with factory supplied alignment strip. • For lengths less than 72", round up to next listed size. No odd size charges apply. • Standard mounting in concealed friction spring clips. • Avail. reverse sizes (face bars parallel to the short side). |