

Model 1000 (A & M)

Installation & Owners Manual

Humidifier
GFI #5730 & 5735

Please Read And Save These Instructions

- Installation by anyone other than a qualified contractor voids the warranty.
- Product designed for residential installation only. Commercial installation voids warranty.
- Modification or alteration of product, parts, installation instructions or local safety codes voids warranty.
 - Read our full warranty policy at the end of this document.



Breathe Healthier

Model 1000 Table of Contents

Table of Contents

Specifications	3
Unit Location	3
Additional Materials That May Be Necessary:	3
Installation	4-5
Installing The Control	5-6
Final Steps Of Installation	7
How The Humidifier Works	7
Maintenance	8
Parts Drawing	8
Humidifier Chassis Cut Out	9
Inside Your Box	9
Trouble Shooting	10
FAQ's	10-11
Limited Warranty	12



WARNING!

This symbol indicates: **IMPORTANT INSTRUCTIONS!**
Failure to heed them can result in serious injury or death.



CAUTION!

This symbol indicates: **IMPORTANT INSTRUCTIONS!**
Failure to heed them can result in serious injury or material property damage.

Specifications

- **Model:** 1000 (A & M) Elite Flow Through Humidifiers (GFI #5730 & #5735)
- **Type:** Fan Powered Flow Through
- **GPD:** 18 Based on 120° F / 49° C Plenum Temperature
- **Warranty (Years):** 10
- **Replacement Vapor Pad®:** GA19 (GFI#7919) (Replace 1-2 times per season)
- **Dimensions (Inches):** 16 W x 16-1/2 H x 10-1/2 D
- **Weight (Pounds):** 15
- **Home Size (Sq. Ft.):** To 3,000
- **Installation:** Warm Air / Return Air Plenum
- **Plenum Opening (Inches):** 14-1/8 W X 12 H
- **Pallet Qty:** 24
- **Cabinet Construction:** UV-Stable Automotive Grade Plastic
- **Humidistat (Included):** "M" Models: MHX3C / "A" Models: GFX3
- **Voltage:** 120VAC
- **In The Box:** "M" Models: MHX3C / "A" Models: GFX3 (Included) Humidifier, Humidistat, Control Bypass Damper, 24V Transformer, Solenoid Valve, Vapor Pad®, Saddle Valve, (GCV3412 Code Valve - A Models), Installation Instructions, Template, Parts.

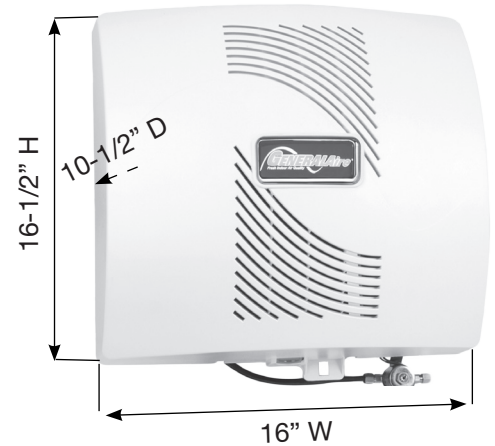

Expected Humidity Performance Coverage in Square Feet Based on Construction Type

Model No.	GPD	Loose (0.75 AC/H)	Average (0.50 AC/H)	Tight (0.30 AC/H)
Elite 570	12	800 Sq. Ft.	1200 Sq. Ft.	2000 Sq. Ft.
Elite 900	17	1115 Sq. Ft.	1650 Sq. Ft.	2800 Sq. Ft.
Elite 1000	18	1175 Sq. Ft.	1770 Sq. Ft.	3000 Sq. Ft.

Humidifier Performance Baseline Criteria

Outside Design Temperature	0° F / -18° C
Outside Design R.H.	70% R.H.
Inside Design Temperature	70° F / 21° C
Inside Design R.H.	30% R.H.
Air Changes/hour (AC/H)	0.30
Ceiling Height (Feet)	8
Furnace Plenum Temperature	120° F / 49° C
Furnace Run Time For Calculating Sq. Ft.	8 Hour /1 Day

Unit Location

- For installation on a vertical surface of the warm air plenum of any forced air furnace.



WARNING: Disconnect electrical power before beginning installation.

- Do not install where temperatures fall below 32°F / 0° C or where plenum temperatures exceed 200° F / 93° C. For maximum evaporative capacity, install this humidifier on the warm air supply plenum.

Additional Materials That May Be Necessary:

1. 1/4" Diameter plastic supply tubing for cold water applications, or 1/4" copper supply tubing for hot water applications
2. Current sensing relay (Model #GA50 - GFI #7026) / or single pole single throw isolation relay
3. Junction box, 115V grounding outlet, cover and wire
4. 1/2" I.D. Drain hose / 3/4" PVC drain
5. #8 Self-piercing sheet metal screws
6. Misc. wire and connectors



Installation

1. Select a location on the vertical surface of warm air plenum of a forced air handling system for mounting humidifier that allows for service and maintenance. Do not install humidifier where the blanked off ends of a cooling coil will restrict air flow to the humidifier. Cut out a square section 12-1/8" tall by 14-1/8" wide as shown.

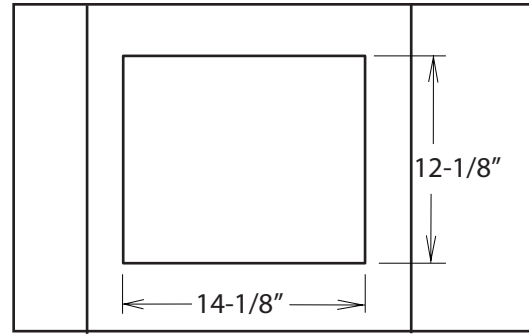

2. Open the cover and remove the evaporator pad assembly. The humidifier chassis is self retaining. Slide the top side in first, then slide the chassis down. Level the chassis and install the eight screws (included).

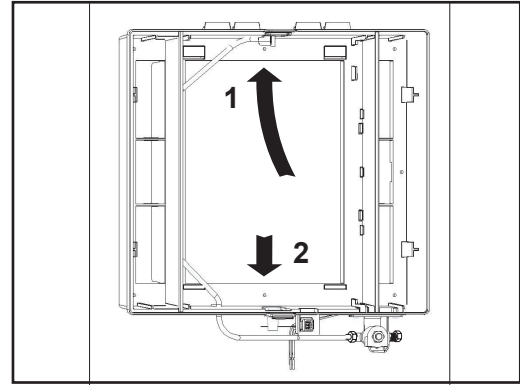

3. Mount the self tapping saddle valve on either a cold or a hot water pipe. A side or top mount is best to avoid clogging from pipe sediment. Connect 1/4" O.D. tubing to the saddle valve. Copper tubing requires a brass compression nut and brass sleeve. Plastic tubing requires a brass insert inside the tubing in addition to a plastic ferrule and brass nut.

CAUTION: do not use plastic tubing on hot water or in contact with any hot plenum surface or duct. Installation of this saddle valve must meet or exceed local codes and ordinances.

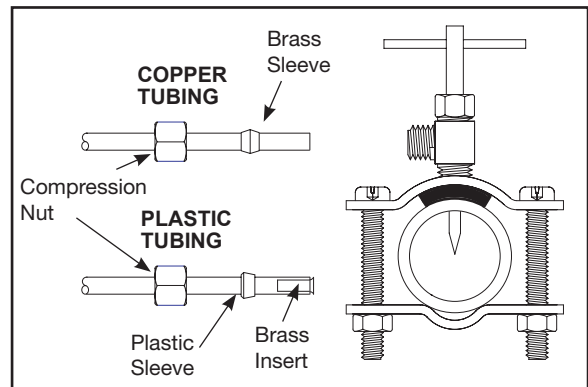

4. Connect 1/4" water supply tube to inlet of solenoid. Connect drain hose to 1/2" spout on humidifier cabinet using hose clamp if necessary. Run 1/2" hose to suitable drain such as floor drain, sewer or laundry sink. Be sure hose has continuous slope and is not kinked at any point.

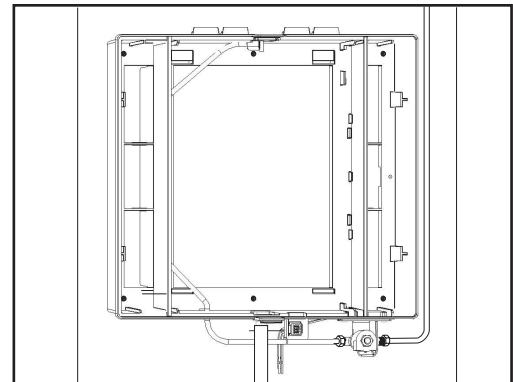

Installation Cont.

5. GCV3412 Code Valve Installation Instructions*

Copper Pipe:

1. **CAUTION:** Turn off water supply.
2. Clean pipe, fittings and valve with sandpaper or wire brush.
3. Apply a thin layer of flux to all surfaces to be soldered.
4. Assemble valve to pipe and/or fittings.
5. Cooling the valve by wrapping a wetted rag around the valve is optional.
6. **WARNING:** For your safety, this should be performed by a licensed contractor only. Heat the joints with a torch. Apply solder to each joint. Continue to apply heat sufficient to keep solder liquid.
7. After solder has filled entire joint area, remove heat and allow joint to cool. Do not move or disturb.
8. Slide compression nut over 1/4" copper tube followed by compression sleeve.
9. Insert tube into valve fully and tighten nut.
10. Turn on water supply and check for leaks.

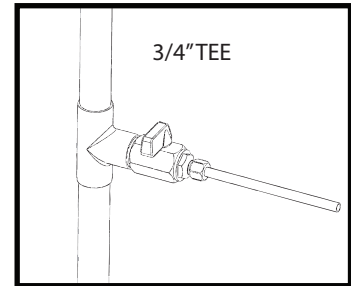
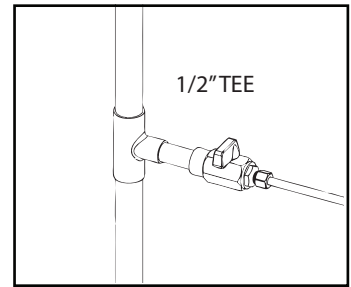

*Code Valve Is Included With Automatic Models Only

Installing The Control

GFX3 (Automatic Models)

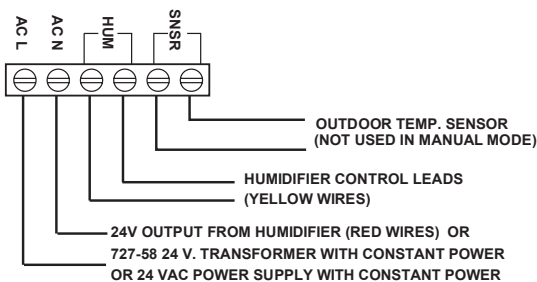

MHX3C (Manual Models)

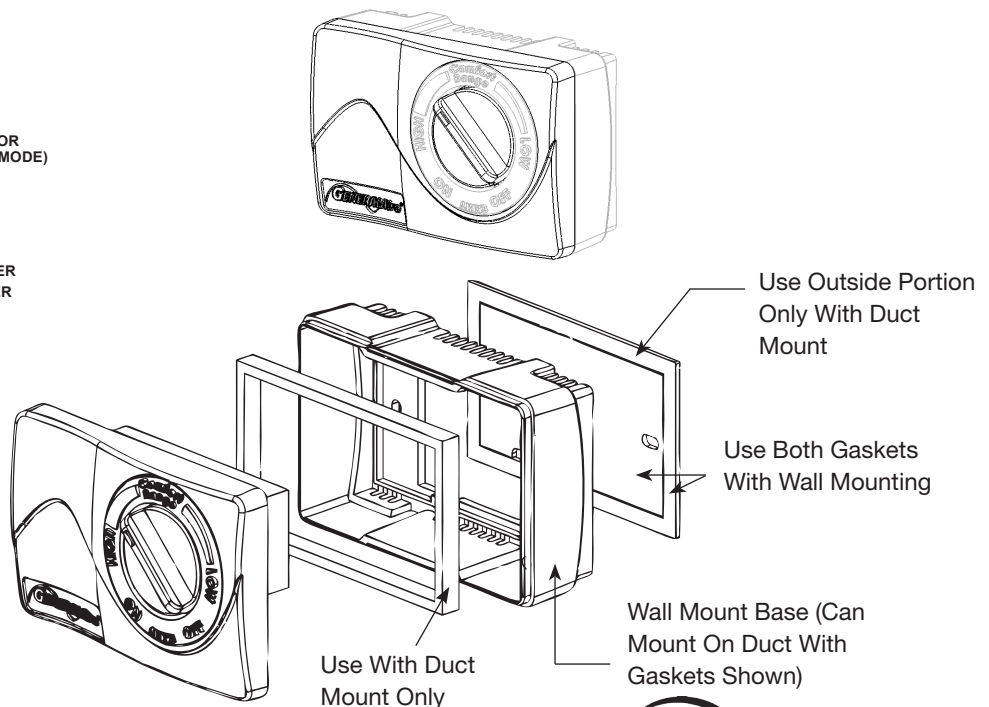

Installing The Control, Cont.

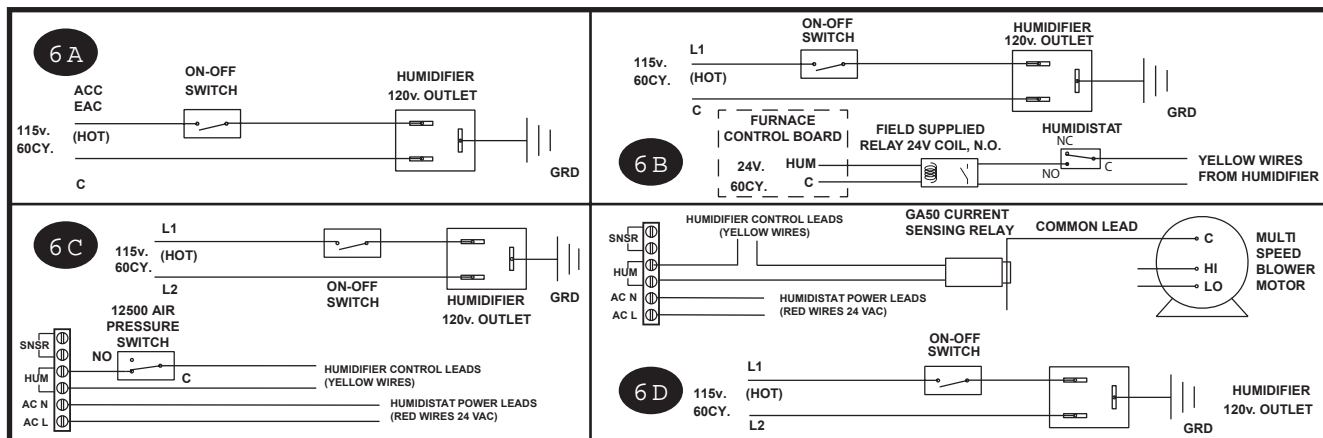

WARNING: All Wiring Should Comply With Local Electrical Codes.

6A With Furnace Circuit Board

Use with mechanical humidistat only. On furnaces with output terminals ACC, or EAC check output voltage to determine that terminals are 115V. Connect on-off switch in series with the hot wire. Install humidistat and connect to yellow wires on humidifier.

6B With Constant Power To Humidifier

Use with mechanical humidistat only. Mount a junction box and 115V grounded outlet. Connect the on-off switch in series with the hot or black wire. Install a field supplied 24V relay and attach to HUM and C on the furnace control board. Install humidistat and connect one side to one yellow wire on humidifier. Connect the other side of the humidistat to one end of switch side of the relay. Connect the other switch side of the relay to the remaining yellow wire on humidifier.

CAUTION: Red humidifier leads are not used for this wiring method.
CAUTION: Do not touch red wires together. Damage to the humidifier will result.

6C With Electronic Humidistat - Pressure Sensing

On furnaces with a two speed blower, the humidifier and a Model 12500 Air Pressure Switch may be wired from a continuous 115V power source. Install the on/off switch in series with hot or black wire and Air Pressure Switch in series with the humidistat circuit. The Air Pressure Switch will detect furnace operation and supply power to the humidifier accordingly.

6D With Electronic Humidistat - Current Sensing

On furnaces with a two speed blower, the humidifier may be wired from a continuous 115V power source. Install the on/off switch in series with the hot or black wire. Install the GA50 Current Sensing Relay in series with the humidistat circuit. The Current Sensing Relay will detect furnace operation and supply power to the humidifier accordingly.

Final Steps Of Installation

- Replace evaporator pad assembly and humidifier cover.

CAUTION: To prevent possible injury, ensure cover is fully seated before continuing to next step.

Insert low voltage six connector wiring harness from cover into chassis solenoid harness.

- Turn on the water supply and plug in the power cord to check operation of humidifier. Set the humidistat to a demand setting. With the furnace off, the solenoid valve should be closed and the humidifier fan not running. Start the furnace, the solenoid valve should open and the humidifier fan run when the blower or burner circuit is energized. Check flow of water through distributor trough and evaporator pad. The standard GA4231 yellow orifice will supply approximately 3.5 GPH of water at a line water pressure of 60 PSI. For low water pressures (20-40 PSI) a larger orifice GA4299 is available to provide the same flow. Leave humidistat set at the recommended setting.

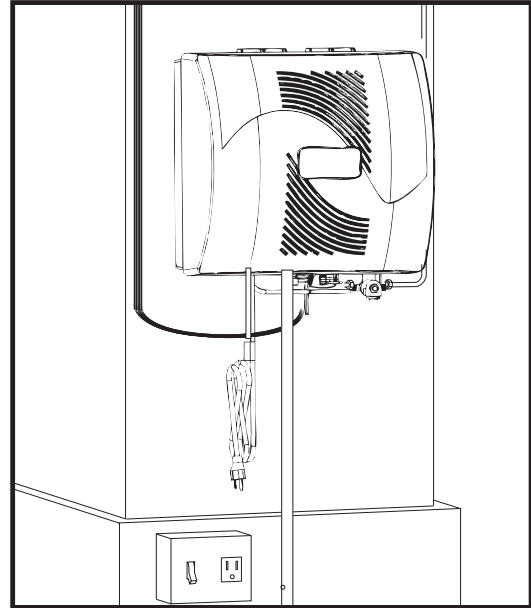

How The Humidifier Works

- The operating principle of the humidifier is based on the most efficient and economical means of evaporating water to the air. The heat necessary for evaporating water is produced by the furnace.
- The water supply to the humidifier is controlled by the electric solenoid valve. The solenoid valve and humidifier fan are controlled by a humidistat connected through an isolation relay. The humidistat is designed for wall mounting in the living area or surface mounting on the return air duct.
- Water flows through a strainer, is metered through an orifice to provide the proper amount of water, and is supplied to the evaporator pad by the distributor trough. Air from the warm air plenum is pulled through the wetted evaporator pad by the humidifier fan and returned to the warm air plenum to be circulated through the living area. Moisture is evaporated to the air passing through the evaporator pad.
- Minerals are not blown into the air stream as occurs in atomizing humidifiers; they are left on the evaporator pad where a high percentage is carried off with the waste water.
- When the humidifier is installed and operating, no adjustments are necessary other than setting the control knob on the humidistat to the desired level of humidification.
- To turn the humidifier off, close the water supply valve, switch the electrical power off, and turn the humidistat off.

At Outside Temperature		Recommended Setting
-20°F	-29°C	15%
-10°F	-23°C	20%
0°F	-18°C	25%
+10°F	-12°C	30%
+20°F	-7°C	35%
+30°F	-1°C	40%

CAUTION: Do not set relative humidity too high during cold weather. Excessive humidity may cause condensation on windows or in walls. Refer to recommended settings as described in the humidistat owners manual.

Maintenance

Your humidifier is engineered to give helpful and trouble-free humidification. For maximum efficiency the following cleaning procedures should be carried out at the end of each heating season:

1. Turn off the water supply and electrical power to the humidifier.
2. Remove cover, water distributor trough, used Vapor Pad®, pad rails and drain pan. Clean excessive mineral deposits from the distributor trough, drain pan, pad rails and humidifier cabinet. A solution of 1/2 vinegar & 1/2 water will help loosen mineral deposits. Inspect drain hose, clean or replace as necessary.
3. Insert a new GA19 Vapor Pad® (GFI# 7919; black notch on top). Install trough, pad rails and drain pan. Replace cover, reconnect electrical plug. Replace Vapor Pad® yearly for peak performance.
4. In heavy mineral areas or if the solenoid valve fails to function disconnect the 1/4" water supply line from the solenoid valve. Carefully pull the strainer screen (GFI #7564) from the valve body. Clean the mineral deposits from all parts. If the orifice is clogged, it may be opened by inserting a small pin. Reinsert the filter into the valve body.
5. Reconnect the 1/4" water line to the solenoid valve if necessary. Turn on the water supply and check all points for leakage. The operation of the unit may be checked by starting the furnace. The humidifier operates only when the furnace blower is running or the burner circuit is energized. The humidifier is now ready for operation.
6. During the summer, turn OFF the water supply and electrical power to the humidifier.

Parts Drawing

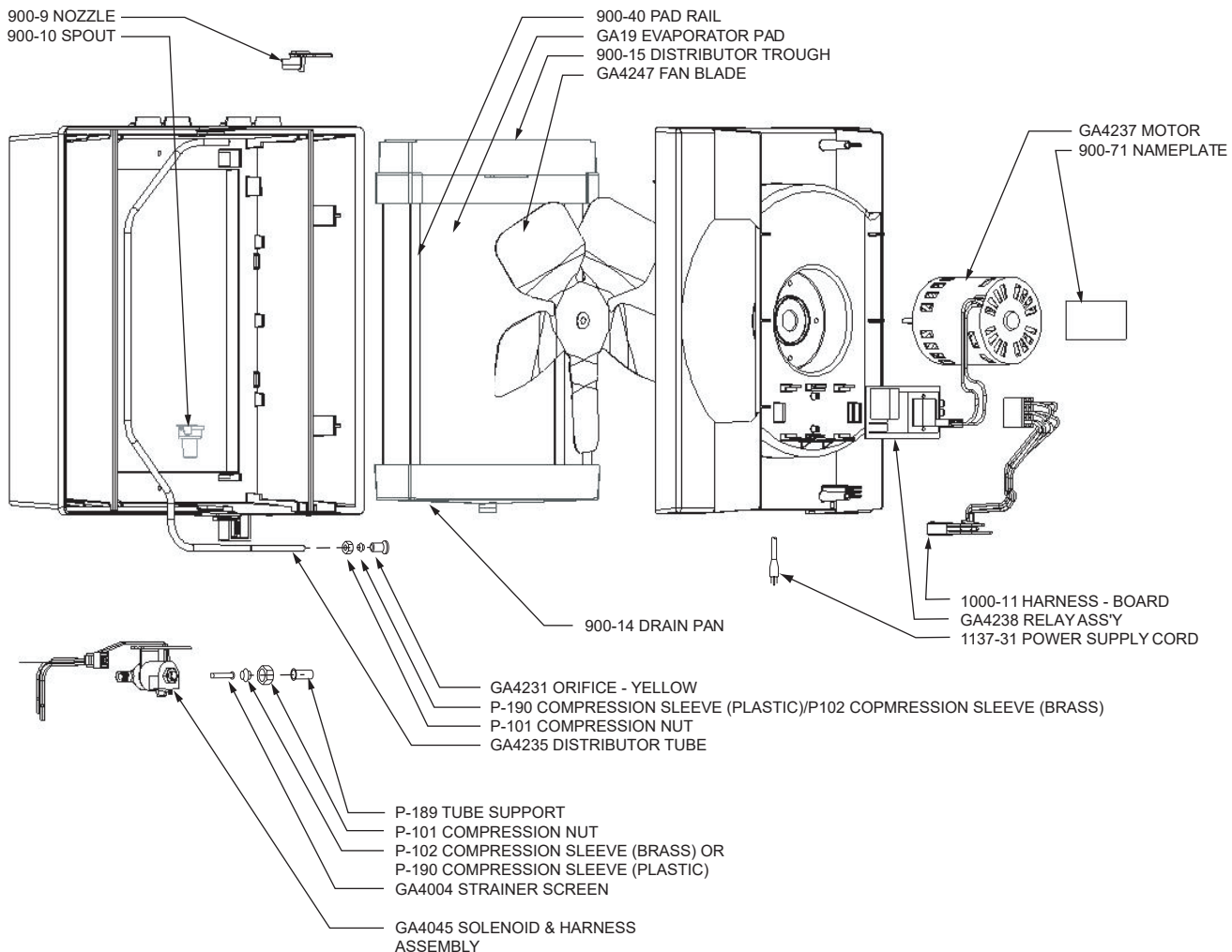

Humidifier Chassis Cut Out

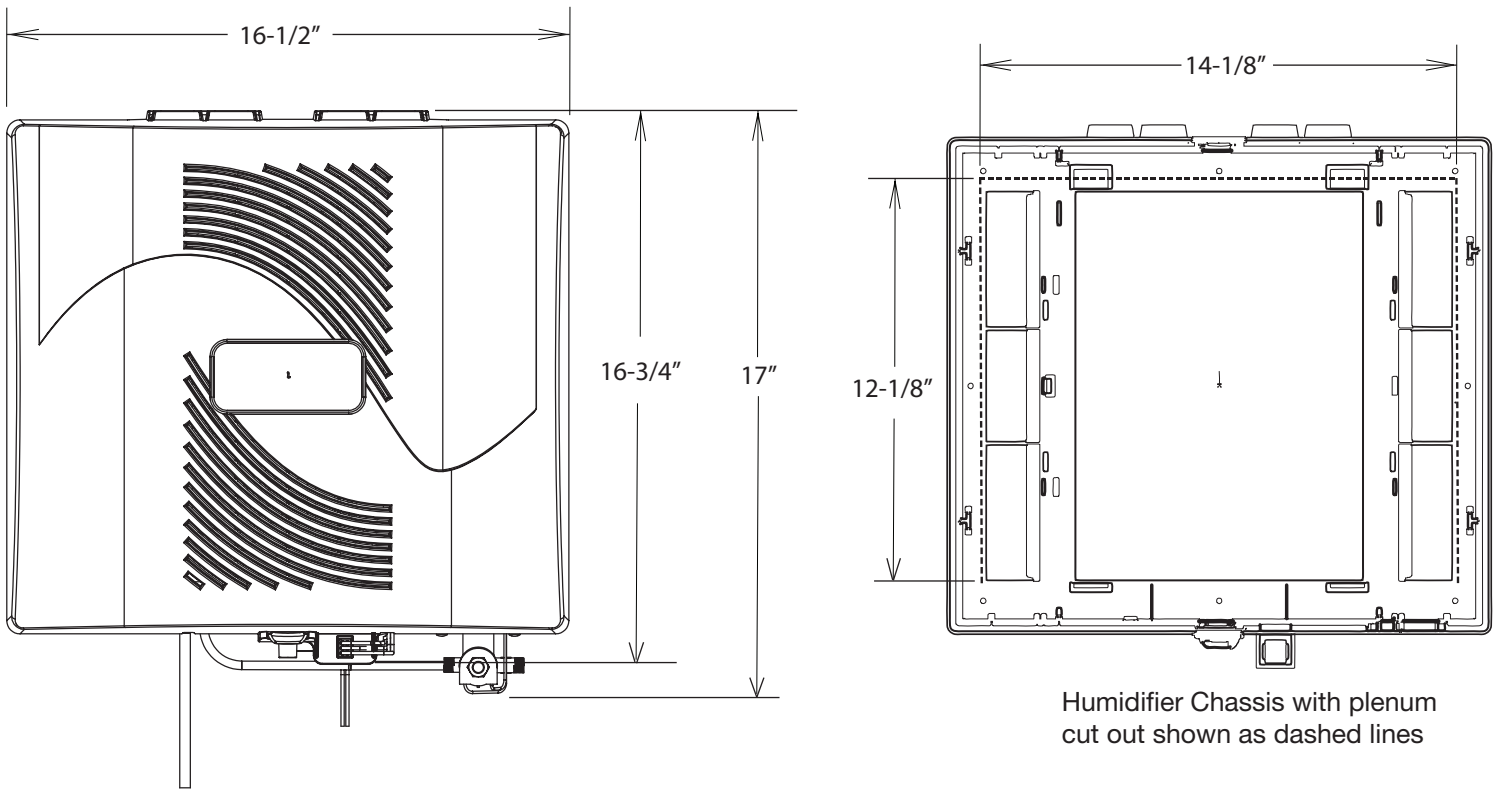

Humidifier Chassis with plenum cut out shown as dashed lines

Inside Your Box

Model 1000A (GFI#5730) includes:

Humidifier components: GA19 Vapor pad, Solenoid Assembly
 Accessories: GFX3 Automatic Digital Humidistat, Code Valve, Saddle Valve

Model 1000M (GFI#5735) includes:

Humidifier Components: GA19 Vapor Pad, Solenoid Assembly, Relay Circuit Board
 Accessories: MHX3C Manual Humidistat, Saddle Valve

Trouble Shooting

1. My humidifier will not operate.

Check for the following:

- Set thermostat to operate both furnace burner and blower. Operation may be necessary for system power.
- Humidity level in home may be higher than humidistat setting. Increase humidity setting on humidistat.
- Verify water supply is on.
- Check for voltage at the solenoid valve. Voltage should be 24VAC.
- Verify wiring of humidifier and humidistat.
- Contact licensed GeneralAire® contractor to verify voltage in and out of the relay board, and replace if necessary.

2. Proper voltage present at solenoid valve (24 VAC) but no water flow.

This can be caused by any of the following:

- Verify water supply is on.
- Verify metering orifice is not obstructed. Very hard water with high mineral content may restrict the metering orifice in as little as one heating season. Replace Yellow metering orifice GA4231 if restricted (GFI #7580).

3. The humidifier runs without furnace operation or humidifier never shuts off.

Check for the following:

- Verify humidifier and humidistat wiring. Humidifier should operate with furnace burner or blower cycle.

4. Too much humidity in home and/or condensation on windows.

- Reduce the setting on the humidistat. Refer to How The Humidifier Works Section of this manual to estimate a humidity setting for the home based on outside temperature (humidistat generally located on furnace return plenum or on an inside wall in the living space).



To ensure your safety and the longevity of your unit, we recommend contacting a licensed contractor to perform any repairs or maintenance.

FAQ's

1. How does a humidifier help with my allergies?

Dry air can lead to a host of problems for allergy and asthma sufferers. Dry climates, winter air, and artificial heat all contribute to the discomfort by drying out your skin, throat and delicate sinus passages and airways (which can contribute to sinusitis). Winter is an especially bad time for dry air as home heating systems, especially forced-air systems, reduce the amount of moisture in the air while humidity levels outdoors typically dip as well.

2. What range of humidity is ideal?

Research shows that 40-60% relative humidity is ideal. Outside this range, your risk of being adversely affected increases.

FAQ's Cont.

3. How often should I change my Vapor Pad®?

We recommend replacing your Vapor Pad® at least once per year. Minerals build up on the Vapor Pad® over time, which in turn:

- Reduces the Vapor Pad's ability to absorb water.
- Prevents the warm air from flowing through the pad. Warm air moving through the water-soaked pad causes the water in the pad to evaporate. It is this process that delivers moisture throughout your home via the home's duct system.

4. Can I clean my Vapor Pad® instead of replacing it?

A coating is applied to the Vapor Pad® that helps it absorb water and control water flow. If you subject the Vapor Pad® to cleaning, you usually remove much of the coating and the pad becomes ineffective. This reduces the output of the humidifier and increases water consumption.

Replace the Vapor Pad® annually.

5. Why would I want to install a humidifier?

For many reasons:

1. Since the air in your home is always trying to reach its saturation point, it will absorb water wherever it can; from the bodies of you and your children, your pets, your furniture and even your house plants. As a result your skin, throat and nasal passages dry out, leaving you more susceptible to physical discomfort, colds, flu and even infection. Allergy and asthma sufferers can be especially affected by air that's too dry.
2. Dry air causes dry, itchy skin.
3. Dry air cracks expensive woodwork, floors, musical instruments, artwork and furnishings.
4. Annoying static electricity (caused by dry air) can damage computers, VCR's and other electronic equipment, requiring expensive repair.
5. Dry air can cause harm to expensive musical instruments like pianos and violins.
6. Dry air causes gaps in window & door frames, letting cold outdoor air in; causing you to turn up the heat and increasing your heating bills! Controlled humidity from the GeneralAire® Humidifier allows you the luxury of dialing the thermostat back & reducing annual heating bills. For example, 68° at 40% relative humidity feels just as warm as 74° at 20% humidity. Setting your thermostat back by as little as three degrees can reduce annual heating bills by as much as 5%.

Limited Warranty

What is Covered

- Ten Years: The 1000 Humidifier is warranted by General Filters, Inc. ("Company") for a period of ten (10) years from the date of the original installation, when installed in residential applications only ("Limited Warranty Period").
- One Year: The Humidistat
- This Limited Warranty runs to the original purchaser of the Product(s) who owns, and resides in, the residential property for which it is installed and maintained.
- The Limited Warranty coverage begins upon the date the Product(s) is installed.
- This Limited Warranty is valid only for the original customer purchasing from Company, and is not transferable.

What is Not Covered

- The following components are not covered by this warranty: Vapor Pads, sleeves or plates, wiring, water strainers or metering orifices.
- This product is designed for residential installation only, therefore, commercial or industrial installations are not covered under this warranty.
- Failure to install the 1000 Humidifier in accordance with these instructions, local codes or ordinances voids the warranty.
- Modifications, changes or alterations to equipment.
- Failure to perform regular maintenance as described in this document voids the warranty.
- This Limited Warranty is valid only for the original customer purchasing from Company, and is not transferable.
- Damage caused by misuse, neglect, fire, wind, mold, damage in transit, or other casualty, contact with corrosive materials (chlorine, fluorine, salt, urine, fertilizers, recycled waste water, or other damaging substances), damage caused during installation, or any cause beyond General Filters, Inc. control is not covered under this Limited Warranty.
- Labor involved in diagnostic calls or in removing, repairing, servicing or replacing parts is not covered under this Limited Warranty.
- Shipping charges are not covered by this Limited Warranty.
- Agreements made by third parties that are not listed in this Limited Warranty.
- Liability for special, incidental, direct, indirect, collateral and consequential damages is excluded. Some states do not allow limitation of incidental damages, so the limitations or exclusions may not apply to you. General Filters, Inc. will not pay electricity or fuel costs, or increases in electricity or fuel costs, for any reason whatsoever, including additional or unusual use of supplemental electric heat. This warranty does not cover lodging expenses or labor charges. General Filters, Inc. shall not be liable for any default or delay in performance under this warranty caused by any contingency beyond its control. This warranty gives you specific legal rights, and you may also have other rights which vary from state to state.

To Make a Warranty Claim / Obtain Service

- Owner must submit a warranty registration within 30 days after installation.
- The Owner must complete our online Return Merchandise Authorization (RMA) Form (www.generalfilters.com/returns), to arrange for applicable Limited Warranty service, within the warranty period. Owner must also provide complete model and serial number, proof of required periodic maintenance, installation date and location and an accurate, detailed description of the problem.
- Owner shall be solely responsible for properly packaging the Covered or Extended Coverage Equipment, for all freight charges, and for all risk of loss associated with shipment.
- Owner is responsible for obtaining a licensed contractor to perform any repairs, maintenance or other work on unit.
- If during the Limited or Extended Warranty Period, Covered or Extended Coverage Equipment fails because of a manufacturing defect, Company will provide a free replacement part to the Owner through a licensed service contractor.

Limitations Of Liability

- General Filters, Inc. makes no express warranties other than the warranty specified above.
- The implied warranties of merchantability and fitness for a particular purpose are limited to the duration listed.
- The manufacturer assumes no liability in connection with the installation or use of the product, except as stated in this Limited Warranty.
- The manufacturer will in no event be liable for incidental or consequential damages.
- This limited warranty gives you specific legal rights, and you may also have other rights which vary from state to state. Some states do not allow either limitations on implied warranties, or exclusions from incidental or consequential damages, so the above exclusion and limitation may not apply to you.

Questions

- Any questions pertaining to this limited warranty should be addressed to the manufacturer. (U.S.A.: The manufacturer has elected not to make available the informal dispute settlement mechanism which is specified in the Magnuson-Moss Warranty Act.)