

COMBINATION FIRE/SMOKE DAMPER

1-1/2 HR (FIRE DURATION RATING)
CLASS 2 (LOW LEAKAGE)
VERTICAL AND HORIZONTAL (INSTALLATIONS)
250°F, 350°F (TEMPERATURE RATINGS)
PARALLEL BLADE (OPERATION)
TO 8.0" W.G. (MAXIMUM STATIC PRESSURE)
TO 4000 FPM (MAXIMUM VELOCITY)
POWER OPEN/SPRING CLOSURE
STANDARD CONSTRUCTION

MODEL FSD-111-2-PB

(RATED PARTITIONS OF 2 HRS OR LESS)

FRAME:

16 GAUGE GALVANIZED STEEL
 INTERLOCKING STACKED HAT SECTION
 CHANNEL FRAME CONSTRUCTION

BLADES:

16 GAUGE GALVANIZED 3"V" FORMED

BEARINGS:

SINTERED BRONZE, OIL IMPREGNATED

AXLES:

1/2" SQUARE ZINC PLATED STEEL STUDS

LINKAGE:

.12 X .50 ZINC PLATED STEEL
 CONCEALED IN THE CHANNEL FRAME

FINISH:

MILL GALVANIZED

BLADE SEALS:

CORROSION RESISTENT STAINLESS STEEL

JAMB SEALS:

CORROSION RESISTENT STAINLESS STEEL

JACKSHAFT:

1/2" DIAMETER ZINC PLATED STEEL WITH
 JACKSHAFT CONNECTOR COUPLING

CAULKING:

UL APPROVED SILICONE SEALANTS:
 DOW CORNING RTV-732, 999A, GE-1200.

OPTIONS:

SLEEVES: RECTANGLE, ROUND, OVAL, AND SPECIALS

ACTUATOR TYPES: ELECTRIC & PNEUMATIC.

ACTUATOR BRANDS: HONEYWELL, SEIBE, LANDIS, BELIMO

ACTUATOR MOUNTING: EXTERNAL AND INTERNAL

OPTIONAL MATERIAL: STAINLESS STEEL CONSTRUCTION

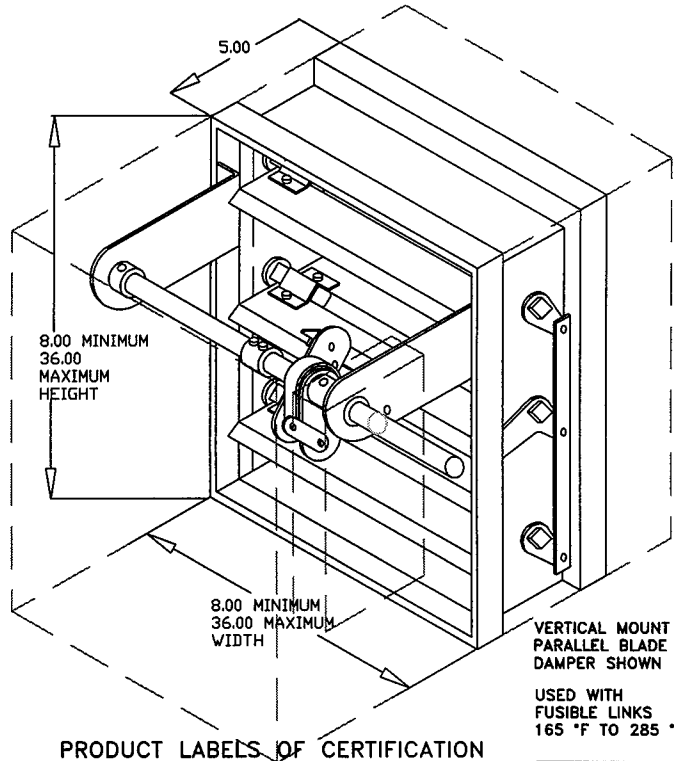

PRODUCT LABELS OF CERTIFICATION

ACCEPTED FOR USE
 CITY OF NEW YORK
 DEPARTMENT OF BUILDINGS
 MEA 215-99-E



CONFORMING TO UL555 AND UL555S
 PERFORMANCE TESTING CERTIFIED
 BY: CERT-AIRE LABORATORIES IN
 ACCORDANCE TO AMCA STD 500.

SINGLE SECTION SIZE AVAILABILITY		MULTIPLE SECTIONS	
MINIMUM	WIDTH X HEIGHT		
	8"	8"	
MAXIMUM	36"	36"	

JOB NAME: _____
LOCATION: _____
ARCHITECT: _____
ENGINEER: _____
CONTRACTOR: _____

10035-REV-C-2

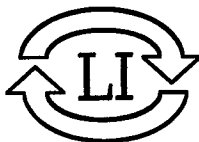

LLOYD INDUSTRIES INC.

231 COMMERCE DRIVE
 MONTGOMERYVILLE, PA. 18936
 TEL: 215-412-4445
 FAX: 215-412-4409
 EMAIL: LLOYDIND@FIREDAMPER.COM

5858 BROADWAY AVE.
 JACKSONVILLE, FL. 32254
 TEL: 904-378-8440
 FAX: 904-378-8441
 EMAIL: LLOYDINDI@BELLSOUTH.NET

WEB SITE: FIREDAMPER.COM