

# DYNAMIC FIRE DAMPER

**1-1/2 HR (FIRE DURATION RATING)**  
**MODEL FD-111-PB**  
**VERTICAL AND HORIZONTAL (INSTALLATIONS) (RATED PARTITIONS OF 2 HOURS OR LESS)**  
**PARALLEL BLADE (OPERATION)**

## STANDARD CONSTRUCTION

### FRAME:

16 GAUGE GALVANIZED STEEL  
 INTERLOCKING STACKED HAT SECTION  
 CHANNEL FRAME CONSTRUCTION

### BLADES:

16 GAUGE GALVANIZED 3"V" FORMED

### BEARINGS:

SINTERED BRONZE, OIL IMPREGNATED

### AXLES:

1/2 SQUARE ZINC PLATED STEEL STUDS

### LINKAGE:

.12 X .50 ZINC PLATED STEEL  
 CONCEALED IN THE CHANNEL FRAME

### FINISH:

MILL GALVANIZED

### BLADE SEALS:

NONE

### JAMB SEALS:

NONE

### JACKSHAFT:

1/2" DIAMETER ZINC PLATED STEEL WITH  
 JACKSHAFT CONNECTOR COUPLING

### CAULKING:

UL APPROVED SILICONE SEALANTS:  
 DOW CORNING RTV-732, 999A, GE-1200.

### OPTIONS:

SLEEVES: RECTANGLE, ROUND, OVAL, AND SPECIALS  
 OPTIONAL MATERIAL: STAINLESS STEEL CONSTRUCTION

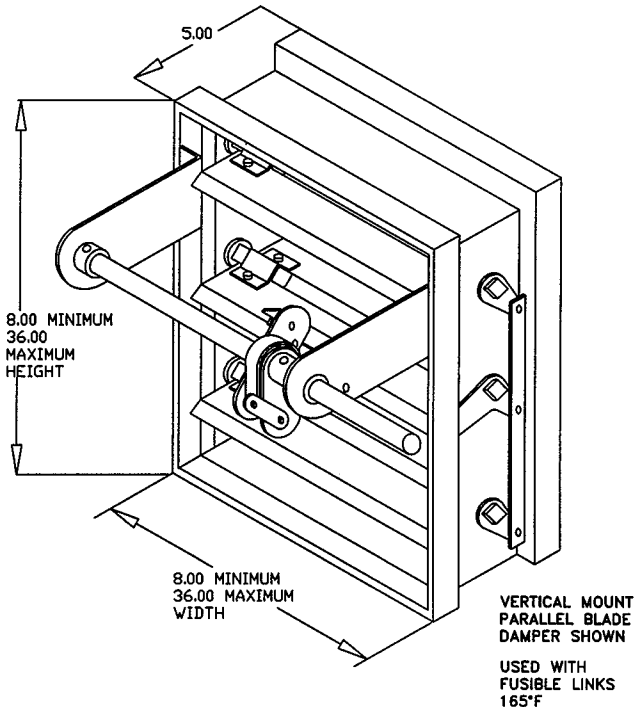

### PRODUCT LABELS OF CERTIFICATION

ACCEPTED FOR USE  
 CITY OF NEW YORK  
 DEPARTMENT OF BUILDINGS  
 MEA 215-99-E



CONFORMING TO UL555  
 PERFORMANCE TESTING CERTIFIED  
 BY: CERT-AIRE LABORATORIES IN  
 ACCORDANCE TO AMCA STD 500.

SINGLE SECTION SIZE AVAILABILITY		
MINIMUM	WIDTH X HEIGHT	
		8"
MAXIMUM	36"	36"

JOB NAME: \_\_\_\_\_  
 LOCATION: \_\_\_\_\_  
 ARCHITECT: \_\_\_\_\_  
 ENGINEER: \_\_\_\_\_  
 CONTRACTOR: \_\_\_\_\_

10152-REV-E-1

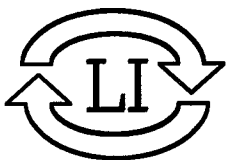

## LLOYD INDUSTRIES INC.

231 COMMERCE DRIVE  
 MONTGOMERYVILLE, PA. 18936  
 TEL: 215-412-4445  
 FAX: 215-412-4409  
 EMAIL: LLOYDIND@FIREDAMPER.COM

5858 BROADWAY AVE.  
 JACKSONVILLE, FL. 32254  
 TEL: 904-378-8440  
 FAX: 904-378-8441  
 EMAIL: LLOYDINDI@BELLSOUTH.NET

WEB SITE: FIREDAMPER.COM